

# REGTEMPER-DI

PC interface for large area temperatures logger

TEMPERATURE LOGGER - INOVONICA / Model : REGTEMPER-DI v3 / SN: 80009

Exit - Open or Creat a sensor net File

SEARCH WINDOW

Sensor number:  Sensor code:  Search

Alarm temperature:  Localization:  Clear

Company:  Identification:  Add

REGTEMPER-DI

Sequence reading rate

2 Seconds  10 Seconds  15 Seconds  30 Seconds  60 Seconds  90 Seconds  120 Seconds

READING MONITOR

Last reading ● Line 1

**FREEZER 1**

Read code sensor

**2803A0FF0000009F**

Readings signaling

Remote Alarm  Loop

READING TABLE ( -55° C < Range < +80° C ) - Class 1 - Service Type A

Line	SENSOR N°	CODE	LOCALIZATION	IDENTIFICATION	ALARM	TEMPERATURE	Date Hour	Man	NPA
1	7	2803A0FF0000009F	FRIGORIFICO DO 1º ANDAR ESQ.	FREEZER 1	-10	-15,000	20/02/2014 09:29:21	<input type="checkbox"/>	1
2	1	28CCC1A40100001F	FRIGORIFICO DO 1º ANDAR ESQ.	FREEZER 2	-10			<input type="checkbox"/>	1
3	19	2820C5A401000054	FRIGORIFICO DO 1º ANDAR ESQ.	REFRIGIRATOR 1	7			<input type="checkbox"/>	1
4	11	28CFBCFF00000020	FRIGORIFICO DO 1º ANDAR ESQ.	REFRIGIRATOR 2	7			<input type="checkbox"/>	1

Activate Configuration Remove line n° RESET SORT EDIT/Load more sensors

INOVONICA\_REGTEMPER-DI/SN:80009 GRAPHIC OF SENSOR N: 7 @FRIGORIFICO DO 1º ANDARE SQ. FREEZER 1 IN 20/02/2014 - FIRM

TEMPERATURE °C

DAY HOUR

Print day Records Print day Alarms

01 2013 19 FREEZER 1

02 2014 20 FREEZER 2

03 2015 21 REFRIGIRATOR 1

mm aaaa dd Identification

Plot the Graphic Print Graphic

Clear Graphic  Markings

2014 © INOVONICA



## INDEX

### 1 - Temperature Measurement

### 2 - Features of the measuring system

### 3 - Applications

### 4 - Configuration / Warranty

#### 4.1 – Serial numbers

#### 4.2 – Warranty

#### 4.3 – Substitution

### 5 - Technical specifications

#### 5.1 - General Specifications

#### 5.2 - Specifications for the agri-food industry

#### 5.3 - Implementation of Sections of the EN 12830

### 6 - Principle of operation

### 7 - Installation

#### 7.1 - Software

#### 7.2 - Hardware

#### 7.3 - Sensors

#### 7.4 - Networking

##### 7.4.1 - Introduction

##### 7.4.2 - Terminology One Wire Network

##### 7.4.3 - Possible topologies

### 8 - Using the Program

#### 8.1 - Identification and preparation of Data Grid

#### 8.2 - System Files

#### 8.3 - Definitions

#### 8.4 - Obtaining Charts

### 9 - UI - Hardware Unit

#### 9.1 - Using the hardware Unit

#### 9.2 - Schematic of the hardware

### 10 – FAQs

### 11 - ANNEX I - Construction and network costs

### 12 - ANNEX II - Using the Software

## 1-Temperature Measurement

Sometimes it is necessary to measure and record temperatures in extensions several meters away from a centralized place without power sources in the remote sensors and where wireless systems cannot be installed due to lack of space or obstruction of the radio signal.

In these conditions are some Hyper - markets, Ice cream, Butchers, Wood treatment, Industries of Machinery, Construction, measurements over long small diameter pipelines.

With the Interface REGTEMPER connected to your PC or Notebook you will perform all these readings in a centralized manner with the records stored in encrypted files.

The configuration of the sensors can even be saved for later use.

For example: you can leave a network of sensors mounted "Off" and with the RJ45 plug accessible to do later new measurements, opening the net of the respective network in the software Menu.

The Logger interface consists of a software and hardware interface that receives the temperatures of the various sensors and do the registration in 24 hours file. A daily file. Temperatures are read sequentially to a pre - selected rhythm. **The encrypted file size of 24 hours readings @ 2s rhythm, is about 1 MB.**

The hardware consists of a UI - Interface Unit equipped with a microcontroller that makes the request for the conversion of temperature to the sensors of the network, responding to the instructions of the Software that runs on the PC.

The software decodes the data and records the temperatures and also records the signaling alarms.

The Alarm sends a command to the Interface Unit to close a contact intended for outdoor signage.

The first version of the Central Logger was designed by specifications of an Ice Cream Shop that wanted to register hourly in a daily profile all temperatures of 50 Freezers, Chests and Showcases which were performed manually.

With this solution the process is simplified and also solved the injury caused by thawing of ice creams from faulty or poorly closed doors, whose alarm signals did not exist.

As REGTEMPER is a computer program it can be connected and accessed by the Internet. You can access it remotely through a program like TeamViewer or others.

The alarm system can trigger an application for sending an SMS that tells the maintenance SUPERVISOR to remotely access the network and verify the fault.

REGTEMPER works with the decimal system separated by commas.

Should be checked the configuration of the decimal separator in the regional settings of your PC in the Control Panel-> Regional Settings.

The lack of this configuration does not allow the graphics to be plotted.

There are two versions of the Interface:

- The **REGTEMPER-DI** that is not a certified version and is intended for unofficial use measurements that do not require reports to officials, for example, the measurement study of the temperatures of the rooms of a house compared to outside temperatures. Temperatures of rooms and machines for computer servers , Tanks with temperature fluids , Measurement study of points of critical temperature control, or Machinery thermal behavior, Greenhouses , HVAC Supervisors .
- The **REGTEMPER-DIc** is a certified version that meets the HACCP standards, the EN12830 for implementation in the food industry: Measuring the temperatures of frozen and chilled foods, cold rooms, Showcases Hypermarkets.

Note: Both models are technically equal in accuracy and quality distinguishing only by the existence or not of a certification required for legal purposes in official entities.

## 2- Features of the measuring system

2.1 - REGTEMPER - D is supplied with one Software (in a Pen) + Hardware (UI) + 10 Sensors CHN.

2.2 - Does the measure of 20 or more daily temperatures in an extension with 400 meters of cable weight.

2.3- In case of failure of power, the system lie to work with the batteries from the laptop or PC UPS fixed. If a fixed PC without UPS is used, the system stops the readings but can start automatically after the return of power from that install a shortcut to run program immediately upon startup of your PC.

2.4 - The Hardware (UI) and the sensors are powered by energy from the PC's USB port.  
No external power supplies are required.

2.5 - The software makes a daily temperature record of each sensor, always starting every 00:00h

2.6 - Timing of consecutive readings (rhythm) from sensor to sensor can be set to 2, 10, 15, 30, 60, 90, 120 seconds. Thus, a network with 70 sensors reading in 10 seconds will range Up  $70 \times 10 = 700$  seconds.

2.7 - Records are archived for 3 years and are automatically deleted at the end of that period.

2.8 - On the day of each file folder there are two file folders: One for archiving files with the temperatures of each sensor and another for the alarms of the day.

2.9 - The alarms continue to be registered even if the command to activate the external alarm is disabled.

2.10 - Lack of power does not remove the log files, or unset the system.

2:11 - Sensors in equipment maintenance can be turned off checking MAN column to avoid false alarms.

2.12 - After selecting a sensor and the date of the measures, access to registers is performed by the button (Print temperatures). There is no possibility to read the records or to change them, because they are encrypted. Changing any symbol of the encrypted files will destroy the file.

The access to print the alarms of the day is via the print alarm button. This access allows you to check all alarms that occurred during a given day. The files of the alarms are not encrypted.

2:13 - The graph of each sensor is obtained by selecting the date and the place of the sensor and pressing, (Plot Graphic) button.

2.14 - If an equipment changes its name or location, the software framework Readings can be edited using the key (EDIT TEXT / Load sensors) . Once rectified, and activated the Configuration the new Net must be saved in the Menu (Save as).

When editing, the program always saves a (XML) file with the previous network configuration by assigning it the name of **Rede0000 date hour minute and second** for protection in case of edition mistake.

To recover, simply go to the root folder C: \ REGTEMPER - D, select and open the file with the date you want.

2:15 - Column NPA is for the branch number where the sensor is installed (extensions 1, 2, 3, 4).

This makes the system to switch to the branch where the sensor.

In models with one branch, NP is always 1.

2:16 - The research of a sensor code/address is made with button (Search).

Only one sensor at a time must be put in the terminals of the interface unit for searching.

The sensor code will appear in the window. Other items can be written in the corresponding windows: Temperature Alarm, Localization and Identification where the sensor will work. Next, do (Add) and data will be transferred to the Data Grid.

2:17 - To delete a line, because the sensor broke, or the place no longer exists, use button (EDIT TEXT / Load sensors) and then select the number of the line to be removed and press (Remove line).

Lines are automatically renumbered and readings continue.

### 3 - Applications

- **Environmental research:** Measuring temperatures in rivers lakes WWTP with cables prepared with embedded sensors and hermetically sealed.
  
- **Ice cream:** Registration and alarm detection of temperatures of all equipment and cold ambient air.  
(For this use we recommend using the certificate model (REGTEMPER - Dc).
  
- **Butchery:** For surveillance and alarm temperatures.  
(For this use we recommend using the certificate model (REGTEMPER - Dc).
  
- **Supermarkets and small markets:** Measuring, record and detect alarms in temperatures of Cold Boxes, Freezers, Display cabinets etc.  
(For this use we recommend using the certificate model (REGTEMPER - Dc).
  
- **Manufacturer of Pools:** Measuring temperatures to verify and optimize the convection currents thus enabling fast uniformity of the overall water avoiding hot and cold zones.
  
- **HAVAC maintenance people:** Measuring temperatures for detecting alarms on several installations of its various customers systems.
  
- **Research laboratories:** To record and study the thermal evolution of processes and tests.
  
- **Installers of equipment that may be subject to heating by deficiency or error of the installation:**  
For example: measuring the temperatures of cables and RF connectors in High Power installation of broadcasting antennas or telecommunications.
  
- **In construction:** for detailed analysis of thermal behavior in buildings insulation, measuring the Inside/Outside temperatures evolution, to look for walls ceilings and floor insulation quality.
  
- **Greenhouses:** of plant cultivation or animal husbandry.
  
- **Manufacturers of thermal energy systems:** energy management for collectors, recording the temperatures at various points in the system.  
It is possible to place sensors inside of pipes and record the thermal behavior of a fluid along that pipe.
  
- **Temperature measurement of deposits:** such as fluid tanks which require careful monitoring.

## 4 - Configuration / Warranty

### 4.1 – Serial numbers

The serial number of the sensors are unique and are configured as follows:  
The last four digits represents the number of the sensor and last digit is the version network.  
The remaining first numbers, represents the network number.

**For example:** If 340009 is the serial number of REGTEMPER-DI.  
Number 340279 marked in the sensor means that sensor number is 27 of the network 34 with version 9.  
There will never exists sensors of REGTEMPER system with equal numbers.

### 4.2 – Warranty

**Warranty of REGTEMPER is for two years.**

### 4.3 – Substitution

After the warranty, new versions of software are free to be downloaded from the Internet.  
For any failure of the UI (Hardware) after the warranty, we will provide one new for a price of €40.00 + VAT (2014 price, plus the annual inflation updates)

## 5 - Technical specifications

### 5.1 - General Specifications

- Type of sensors: Digital sensors DS18B20 housing..... T0- 92 with 2m cable harness
- Weight of the network: ..... 400metros. (See Note 1)
- Number of sensors ..... = (400m - Meters of cable installed) / 2.5 (See Note 2)
- Number of Primary Trunks: 1 or 4 depending on the model with RJ45 (See Annex I) outputs
- The temperature range of - 55 ° C to 80 ° C
- Accuracy: ..... + - 0.5 degrees between -10 ° C and 80 ° C
- Rhythm of measurements: from 2 seconds to 120 seconds
- Logging Interval ..... = Number of sensor readings x Rhythm
- Fluid Measure: Depends on the encapsulation used in sensors
- Software: - REGTEMPER-DI
- Firmware: REGTEMPER\_F (V1.10)
- Main Hardware: UI with microcontroller
- Communication with PC: USB
- Communicating with the sensors: Protocol "Maxim / DALLAS One Wire"
- Voltage and maximum current of alarm terminals UI: 100 V 500 mA
- Cable Capacity / meter: 52 pF / m (See point 7.4)
- Parasite capacity of each sensor ..... 25pF
- Recommended cable: UTP CAT 5 or CAT6
- UTP cable impedance: 100 Ohms
- Error measures:  $CRC = X^8 + X^5 + X^4 + 1$  (Cyclic Redundancy Checks of Maxim iButton)

#### Note1:

The weight of cable is the total number of metres of existing cable installation. (See 7.4.2)  
In a network with 10 sensors, each with 2,5m of weight, it can be installed 375 meters of cable:  
Cable installed =  $400 - (2.5 \times 10) = 375$  m

#### Note2:

If you intend to install a network with 100 sensors, the cables and extension cords will total:  
Installed cable = 150 meters =  $400 - (100 \times 2.5)$   
The more sensors are used, the lower the distance of the network.

## 5.2 - Specifications for the food industry

- Environment Climate: type A.
- Accuracy Class: Class 1, and better than  $\pm 0.5^{\circ}\text{C}$ ,  $-10^{\circ}\text{C}$  to  $+80^{\circ}\text{C}$ .
- Type service: S (Storage).
- Response time: 30 seconds with CHN encapsulated sensor with sheath 304 stainless steel.
- Measuring range: Meets point 4.2 of EN12830.
- Measurement range: 135K (between  $-55^{\circ}\text{C}$  and  $+80^{\circ}\text{C}$ ).
- Records Charts: Comply No. 1 of Article 9 of Decree 1129/2009.
- Time of Registration of each file: 24 Hours
- Logging interval: Meets NP12830 4.9.2.2.
- UI Hardware box material: ABS plastic IP54 for air conditioning / office with the PC environment.

## 5.3 - Implementation of EN12830 Sections

### - Section 4.1

REGTEMPER is an autonomous system and is independent of any temperature measurements of the cooling systems where it will be installed.

### - Section 4.2

The measuring range (Gama) of REGTEMPER is 135K (  $-55^{\circ}\text{C}$  to  $+80^{\circ}\text{C}$  )

### - Section 4.3

Registrations begin at 0:00 each day, and the date of the records will be plotted in the header of graphics as well as the Location and Identification of the respective sensor.

### - Section 4.4.1

The REGTEMPER records the temperature and the group Date / time at which the measurement is processed. Data files are identified by the sensor Identification in the folders of Years, Month, Days, hours - minutes - seconds that the measurements were made.

### - Section 4.4.2

The Graphics of REGTEMPER are obtained immediately by sensor per day, month and year, with the equipment identification: model and serial number. For certified models the number of certification of conformity will be shown in the Graphic header. Graphics and the lists of measurements can be printed.

### - Section 4.5

The power supply of the hardware (UI) is from the PC or a Notebook PC that features the state charge of battery. The battery from the laptop works as a buffer(UPS) in case of a power failure, thus ensuring system autonomy during the interruption.

### - Section 4.6

The protection degree of the enclosure of the UI IP20 required for equipment that work in HAVAC medium.

### - Section 4.8.1

Power to the UI is 5V, obtained from the PC USB port. The remote sensors are fed with the same 5 Volts via the CAT5/6 network cable.

### - Section 4.8.4

If power fails, data continues to be recorded due to the battery of the Notebook or PC UPS installed for purposes of protection. If there is a long power failure at all, no loss of any record data is lost.

### - Section 4.9.2.1

REGTEMPER is a Class 1 type meter, because it uses the digital sensor DS18B20 DALLAS / Maxim , whose error is  $\pm 1^{\circ}\text{C}$  in the range of  $-55^{\circ}\text{C}$  to  $-10^{\circ}\text{C}$ . and  $\pm 0.5^{\circ}\text{C}$  in the range  $-10^{\circ}\text{C}$  to  $85^{\circ}\text{C}$  . The resolution is  $0.125^{\circ}\text{C}$ .

**- Section 4.9.2.2**

REGTEMPER is an interface for fixed computers to measure and record temperatures of stored products ( Class S ) and a climatic Environment Type A. It meets the requirement of a Logging Interval of 30 minutes  
The maximum number of sensors (With 2m whips) technically possible to install in the network is  $N = 400 / 2.5 = 160$  sensors .

**- Section 4.9.2.3**

The records of REGTEMPER are performed in each 24 hours starting at 00:00 .

The maximum capacity of daily readings is  $(24 \times 60 \times 60) / 2 = 43200$  readings corresponding to an occupancy ~ 1 MB of memory.

All records are kept for 3 years from date of which will be automatically deleted from the system to release memory.

**- Section 4.9.2.4**

REGTEMPER records for 24 hours and meets the maximum error of 0.2% corresponding to 172.8 seconds / day, because it is controlled by the PC clock and the crystal oscillator of the microcontroller of the UI.

**- Section 4.9.2.5**

The response time required for the temperature registration of stored products is 20 minutes.

REGTEMPER has a response time of about 30 seconds with an encapsulation in Stainless steel sheath CHN 304. For sensor CH316 it have 60 Seconds response time with encapsulation of stainless steel 316 and for sensor CHCU it have 120 seconds with sheath of copper CHCU.

**- Section 4.9.3.1**

REGTEMPER is a Register for Type A climatic environment because:

- It is used to measure and record the temperature of the product in fixed storage with external sensors over large distances.
- The Interface Unit (UI) and the PC are used outside the fridges in a room with air conditioning and temperature conditions for human habitability. Sensors are installed inside and outside of refrigeration equipment.
- The recording device - Computer - has an active normal temperature of working between 5 ° C and 40 ° C.
- The boundary conditions of storage of sensors and PCs when supports the temperature range from -20 ° C to +60 ° C.

**- Section 4.9.3.2**

REGTEMPER was designed to work in fixed, standard office type A climatic environment.

It was not designed to operate in transport vehicles and therefore was not subjected to the tests specified in this paragraph.

**- Section 4.9.3.3**

REGTEMPER was designed to work in stationary regime, in standard office type A climatic environment.

It is not designed to operate with mechanical vibration so, was not subject to the tests prescribed in paragraph 5.6.6 of the EN 12830.

**- Section 4:10**

Data recorded temperatures are stored encrypted and modification is not possible, because any change in file characters will disables the file.

Access to the temperature registration list or access to graphic display, is done through software that decrypts the data, formatting them for normalized appearance according to the specifications of EN12830.

## 6 - Principle of operation

In the Data Grid of the sensor network, the readings are recorded line by line for each sensor. When it reaches a temperature of alarm, the UI closes the contact that may trigger an external alarm or activate some kind of Temperature controller. The sensor in alarm condition is signaled by a red color of the window.

The sensors are configured with the Alarm temperature, Identification and Localization. These can be edited in the Data Grid, by clicking with the mouse in the respective windows to change to the new settings. In the READINGS MONITOR, readings are viewed with a signaling type Led. Led in Red - identifies that reading was performed and recorded. LED off - represents the moment in which it is to be read and converted a temperature. A brown slider bar allows you to view where the readings are in the Data Grid. The time of the alarm can be adjusted in the UI to a maximum duration of 45 seconds, because in some cases only a few seconds of alarm is enough to perform a human action avoiding long time of signalization. The alarm can be stopped any time through the RESET button located on the side of the UI. In the software, you can also disable the sending of alarms to the outside, getting it permanently inoperative. However, the registration of the alarms will be processed normally.

## 7 - Installation

### 7.1 – Software

The program installation is done by clicking on the Windows Icon Installer, leaving it to run the installation. The installation creates folders in a directory C: \ REGTEMPER - DI.

After installation it appears on the desktop the Icon:



### 7.2 - Hardware

The UI is the hardware of the REGTEMPER system, without which, the software has no application. The UI is powered by the power supplied of the USB Port, and this, in turn, feeds the sensor network. Before starting the program the UI must be connect to one of the PC USB ports. The PC will detect automatically the UI through the HID protocol. In some Windows 8 or 8.1 it will be necessary to deactivate the USB (Intel xHCI Mode). See FAQ 3.

### 7.3 - Sensors

1 - The sensors have a protective stainless steel sheaths to use in almost all environments. The extensions whips of the sensors supplied have two meters. The system is supplied with 10 stainless steel 304 CHN sensors with RJ45 male connectors at the ends.

Figure shows one CHN sensor # 3 of network # 1.



## 7.4 – Networking

### 7.4.1 Introduction

The One- Wire Protocol Maxim - DALLAS was initially developed for intercommunication between devices near something like CAN or I2C protocol.

In practice, it has been found that the distance measurements increases when there is a good impedance matching and a proper pull- up of the supply to the network.

It was also found that it is not the linear distance (radius) that affects the dimensioning of the network, but the number of meters of used cable (weight), because the introduced parasitic capacitance of the cable.

The characteristic of 52 pF / m is the capacity per meter of CAT5 UTP cable means that for every 52 pF inserted for any devices in the network, it will assumes that capacity as one meter of cable in the network.

Therefore, as a DS18B20 sensor have a parasitic capacitance of about 22pF, it means half a meter inserted in the network.

For the network performance, it must be calculated the relation of meter cable used (weight) with relation to the number of sensors to be used. See the examples in Notes 1 and 2 of **Section 5.1** .

### 7.4.2 - Terminology One- Wire networks

As explained before, there are two basic terms that define the One- Wire Network which are the **Radius** and the **Weight**.

**Radius** - is the cable distance between the UI and the farthest sensor.

**Weight** - is the number of meters of cable and whips that are installed in the network.

Therefore, the distance of 400 meters stated in the characteristics do not represent the linear distance (radius) of a network, but the amount of the installed cable (weight).

Only in the case of a network with linear topology the radius will be equal to the weight.

### 7.4.3 - Possible topologies

Example of DTUB topology that runs the installation

Total trunk cable = 352m + (24 sensors x 2m) = 400 meters Weight

Radius = 354 m or (352 m +2m) (Sensor weigh of 0,5m is not considered for simplicity)

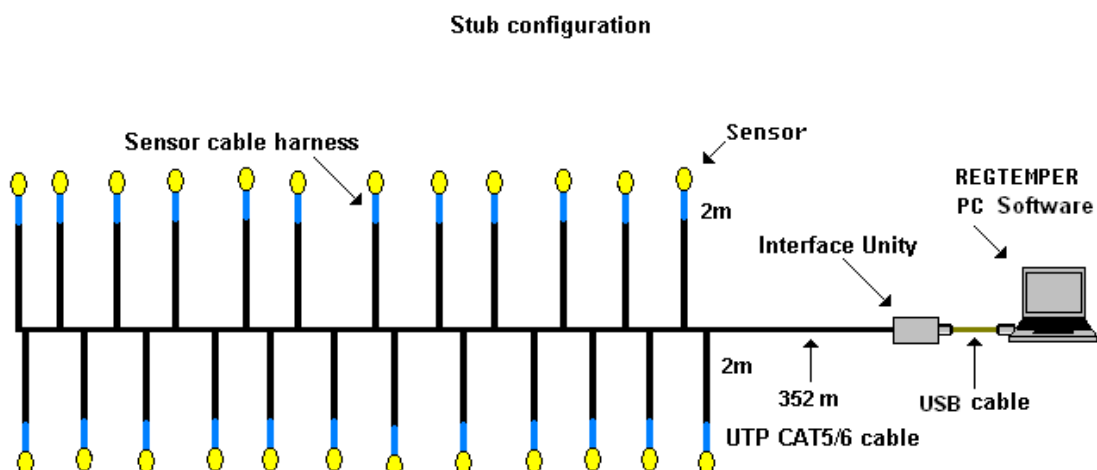

Note : Principal Trunk wil, have 400 - (24 x 2) = 352 meters

LINEAR topology - sensors are applied directly to the cable Weight and Radius = 400 m  
(Sensor weigh of 0,5m is not considered for simplicity).

**Linear configuration - Sensors are placed directly on the cable**

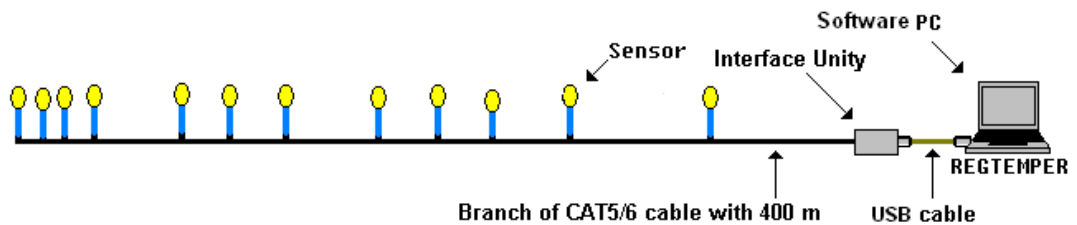

This configuration allows measuring the temperature of fluids in pipes and ducts

## 8 - Using the Program

### 8.1 – Data Grid identification and preparation

First, the UI must be connected to the USB Port of PC



Then we click on the icon in the desktop to run the program.

For the identification of sensors codes, connect only one sensor at a time to the RJ45 terminal of the UI. Press Search button and the sensor unique code will appear in the window as shown in next figure.

The screenshot shows the 'TEMPERATURE LOGGER INOVONICA - Model: REGTEMPER-DI / SN: 80009' software interface. The 'SEARCH WINDOW' is active, showing a 'Sensor number' of 23 and a 'Sensor code' of 2864ABFF00000A9. The 'Search' button is highlighted with a red circle. The 'READINGS MONITOR' shows a 'Last reading' of 'FREEZER' and a 'Read code sensor' of '28CC1A40100001F'. The 'READING TABLE' is empty. The interface includes various controls like 'Activate Configuration', 'Remove line n°', 'RESET', 'SORT', and 'EDIT/ Load more sensors'. The bottom status bar shows 'CRC 63', 'Print day Records', 'Print day Alarms', and date/time settings.

Next fill the sensor number, the Localization, Identification and also the temperature of alarm.  
Clicking Add, you enter all the information to the Data Grid.

LOCALIZATION of a sensor is in general, the place where it is.  
For example: Pavilion3 Room 3.2.

IDENTIFICATION define exactly where the sensor is installed and the function which will be plotted in the graphics.  
For example: Showcase of meat. 3rd shelf.

The sensor number is represented by the last 4 digits of the markers stapled on it.  
Sensor marked with 80239, is the sensor # 0239 of the Network with number 8.  
The last # 9 is the version of network and can be discarded from the sensor number.

In this example, the REGTEMPER Network is # 8 and the Serial Number of the system is 80009.  
The number of sensor to be inserted in the panel will be # 23.  
If you do not enter any sensor numbers, the program assigns the #1 to the 1st sensor inserted and so on.

The screenshot shows the 'TEMPERATURE LOGGER INOVONICA - Model: REGTEMPER-DI / SN: 80009' interface. At the top, there's a title bar and a menu option 'Exit - Open or Creat a sensor net File'. Below this is a 'SEARCH WINDOW' with fields for 'Sensor number' (23), 'Sensor code', 'Alarm temperature', 'Localization', 'Company' (LIDL), and 'Identification'. There are 'Search', 'Clear', and 'Add' buttons. The 'Add' button is circled in red. Below the search window is a 'Sequence reading rate' section with radio buttons for 2, 10, 15, 30, 60, 90, and 120 seconds. To the right is a 'READINGS MONITOR' section showing 'Last reading' as 'Line 2' with a 'FREEZER' label and a 'Read code sensor' value of '28CCC1A40100001F'. Below this is a 'READINGS TABLE' with columns: Line, SENSOR N°, CODE, LOCALIZATION, IDENTIFICATION, ALARM, TEMPERATURE, Date Hour, Man, and NPA. The first row is circled in red and contains: 1, 23, 2864ABFF000000A9, and 0. At the bottom, there are buttons for 'Activate Configuration', 'Remove line n°' (set to 1), 'RESET', 'SORT', and 'EDIT/ Load more sensors'. There are also 'Print day Records', 'Print day Alarms', and 'Plot the Graphic' buttons. The bottom left shows 'CRC 63' and '2014 © INOVONICA'. The bottom right shows 'mm', 'aaaa', 'dd', 'Identification', 'Plot the Graphic', 'Print Graphic', 'Clear Graphic', and 'Markings'.

One proceeds similarly with all other sensors.

TEMPERATURE LOGGER INOVONICA - Model: REGTEMPER-DI / SN: 80009

Exit - Open or Creat a sensor net File

SEARCH WINDOW

Sensor number: 23    Sensor code:    Search

Alarm temperature:    Localization:    Clear    **REGTEMPER-DI**

Company: LIDL    Identification:    Add

Sequence reading rate

2 Seconds     10 Seconds     15 Seconds     30 Seconds     60 Seconds     90 Seconds     120 Seconds

READINGS MONITOR

Last reading ● Line 4

**REFRIGIRATOR**

Read code sensor

**28CFBCFF00000020**

Readings signaling

Remote Alarm     Loop off

READING TABLE (-55° C < Range < +80° C) - Class 1 - Service Type A

Line	SENSOR N°	CODE	LOCALIZATION	IDENTIFICATION	ALARM	TEMPERATURE	Date Hour	Man	NPA
1	7	2803A0FF0000009F	FRIGORIFICO DO 1º ANDAR ESQ.	FREEZER	-10	-19,250	19/02/2014 18:00:28	<input type="checkbox"/>	1
2	1	28CCC1A40100001F	FRIGORIFICO DO 1º ANDAR ESQ.	FREEZER	-10	-19,375	19/02/2014 18:00:30	<input type="checkbox"/>	1
3	19	2820C5A401000054	FRIGORIFICO DO 1º ANDAR ESQ.	REFRIGIRATOR	10	7,375	19/02/2014 18:00:32	<input type="checkbox"/>	1
4	11	28CFBCFF00000020	FRIGORIFICO DO 1º ANDAR ESQ.	REFRIGIRATOR	10	2,625	19/02/2014 18:00:26	<input type="checkbox"/>	1

REGTEMPER-DI

THIS CONFIGURATION CLEARS THE PREVIOUS ONE! DO YOU CONFIRM?

OK also to create a Start File

Sim    No

Activate Configuration    Remove line n°: 4    RESET    SORT    EDIT/Load more sensors

CRC: 00    Print day Records    Print day Alarms    01 2013 01 FREEZER  
02 2014 02 FREEZER  
03 2015 03 REFRIGIRATOR  
mm aaaa dd Identification

Plot the Graphic    Print Graphic

Clear Graphic     Markings

2014 © INOVONICA

Finally, after inserting all sensors, Click on Activate Configuration -> Yes and the program will starts with the readings at the selected rhythm.

To save this Network settings go to the Menu -> Save As, to save the network permanently with a name. Do not forget this detail.

TEMPERATURE LOGGER INOVONICA - Model: REGTEMPER-DI / SN: 80009

Exit - Open or Creat a sensor net File

New    Ctrl+N

Open    Ctrl+O

**Save as ...**

Exit

Sensor code:    Search

Localization:    Clear    **REGTEMPER-DI**

Company:    Identification:    Add

Sequence reading rate

2 Seconds     10 Seconds     15 Seconds     30 Seconds     60 Seconds     90 Seconds     120 Seconds

READINGS MONITOR

Last reading ● Line 2

**FREEZER**

Read code sensor

**28CCC1A40100001F**

Readings signaling

Remote Alarm     Loop off

READING TABLE (-55° C < Range < +80° C) - Class 1 - Service Type A

Line	SENSOR N°	CODE	LOCALIZATION	IDENTIFICATION	ALARM	TEMPERATURE	Date Hour	Man	NPA
1	7	2803A0FF0000009F	FRIGORIFICO DO 1º ANDAR ESQ.	FREEZER	-10	-19,250	19/02/2014 18:02:00	<input type="checkbox"/>	1
2	1	28CCC1A40100001F	FRIGORIFICO DO 1º ANDAR ESQ.	FREEZER	-10	-19,375	19/02/2014 18:01:54	<input type="checkbox"/>	1
3	19	2820C5A401000054	FRIGORIFICO DO 1º ANDAR ESQ.	REFRIGIRATOR	10	7,500	19/02/2014 18:01:57	<input type="checkbox"/>	1
4	11	28CFBCFF00000020	FRIGORIFICO DO 1º ANDAR ESQ.	REFRIGIRATOR	10	3,000	19/02/2014 18:01:58	<input type="checkbox"/>	1

Activate Configuration    Remove line n°: 4    RESET    SORT    EDIT/Load more sensors

CRC: 00    Print day Records    Print day Alarms    01 2013 01 FREEZER  
02 2014 02 FREEZER  
03 2015 03 REFRIGIRATOR  
mm aaaa dd Identification

Plot the Graphic    Print Graphic

Clear Graphic     Markings

2014 © INOVONICA

In the case of readings be "Line off or shunted", is because the network is not yet connected to the UI.

## 8.2 - System Files

Archived files are not normally accessible and are impossible to change.  
The lists of records or daily charts of each sensor can only be read by software.  
Every three years, the system automatically clears all previous records.

## 8.3 - Definitions

Logging interval is the time between the readings from the same sensor.  
Is the time rate of successive readings between different sensors.

Formula to calculate the pace depending on the Logging interval and the number of sensors to measure will be:

$$\text{Rhythm measures} = \frac{\text{Logging interval}}{\text{N}^{\circ} \text{ of sensors}}$$

The record maximum range for measurements of items in storage in the agri-food Industries is 30 minutes, which means you can use 900 sensors a rhythm of 2 seconds is selected, and only 15 sensors, if a rhythm is selected 120 seconds.

Note: The system does not involve more than 160 sensors with whips of 2 meters.

## EXAMPLES OF REGISTRATION INTERVAL AND RHYTHM OF READING

### Example 1 – ICE CREAM SHOP

8 Chest freezers must be measured with interval record of 3 minutes.

3 minutes = 180 seconds

The Rhythm of the measurements to be selected must be calculated according to the formula :

Rythm =  $180/8 = 22.5$  seconds

We will select 15 or 30 seconds.

**The encrypted file size of 24 hours readings @ 2s rhythm, is about 1 MB.**

### Example 2 MACHINERY

We check the thermal evolution on 20 points of an industrial machine for one hour (3600 seconds).

The maximum will select the Rhythm =  $3600/20 = 180$ s

Seleccionaríamos either less than 180 seconds rhythms depending on the desired accuracy and speed .

With a Rhythm 2 seconds would get 90 readings for each sensor for an hour , which would give a graph with good resolution .

## 8.4 - Obtaining Charts

TEMPERATURE LOGGER INOVONICA - Model: REGTEMPER-DI / SN: 80009

Exit - Open or Create a sensor net File

SEARCH WINDOW

Sensor number: 23    Sensor code:    Search

Alarm temperature:    Localization:    Clear

Company: LIDL    Identification:    Add

REGTEMPER-DI

Sequence reading rate

2 Seconds     10 Seconds     15 Seconds     30 Seconds     60 Seconds     90 Seconds     120 Seconds

READINGS MONITOR

Last reading: ● Line 2

FREEZER

Read code sensor: 28CC1A40100001F

Readings signaling     Remote Alarm     Loop off

READING TABLE ( -55° C < Range < +80° C ) - Class 1 - Service Type A

Line	SENSOR Nº	CODE	LOCALIZATION	IDENTIFICATION	ALARM	TEMPERATURE	Date Hour	Man	NPA
1	7	2803A0FF0000009F	FRIGORÍFICO DO 1º ANDAR ESQ.	FREEZER	-10	-19,125	18/02/2014 18:04:31	<input type="checkbox"/>	1
2	1	28CC1A40100001F	FRIGORÍFICO DO 1º ANDAR ESQ.	FREEZER	-10	-19,375	18/02/2014 17:38:01	<input type="checkbox"/>	1
3	19	2820C5A401000054	FRIGORÍFICO DO 1º ANDAR ESQ.	REFRIGIRATOR	10	8,125	18/02/2014 17:35:55	<input type="checkbox"/>	1
4	11	28CFBCFF00000020	FRIGORÍFICO DO 1º ANDAR ESQ.	REFRIGIRATOR	10	4,500	18/02/2014 17:35:57	<input type="checkbox"/>	1

Activate Configuration    Remove line nº:    RESET    SORT    EDIT/ Load more sensors

CRC: 00    Print day Records    Print day Alarms    01 ↑ 2013 ↑ 01 ↑ FREEZER    Plot the Graphic    Print Graphic

02 ↓ 2014 ↓ 02 ↓ FREEZER

03 ↓ 2015 ↓ 03 ↓ REFRIGIRATOR

mm    aaaa    dd    Identification

2014 © INOVONICA

To obtain a graph of a given sensor and date, simply select the date sensor, whose graph to get and then press Plot the Graphic button. The graphic will remain in the monitor without disturbing the readings of the system. The Graphics can be printed.

TEMPERATURE LOGGER - INOVONICA / Model: REGTEMPER-DI v3 / SN: 80009

Exit - Open or Create a sensor net File

SEARCH WINDOW

Sensor number:    Sensor code:    Search

Alarm temperature:    Localization:    Clear

Company:    Identification:    Add

REGTEMPER-DI

Sequence reading rate

2 Seconds     10 Seconds     15 Seconds     30 Seconds     60 Seconds     90 Seconds     120 Seconds

READINGS MONITOR

Last reading: ● Line 1

FREEZER 1

Read code sensor: 2803A0FF0000009F

Readings signaling     Remote Alarm     Loop

READING TABLE ( -55° C < Range < +80° C ) - Class 1 - Service Type A

Line	SENSOR Nº	CODE	LOCALIZATION	IDENTIFICATION	ALARM	TEMPERATURE	Date Hour	Man	NPA
1	7	2803A0FF0000009F	FRIGORÍFICO DO 1º ANDAR ESQ.	FREEZER 1	-10	-15,000	20/02/2014 09:29:21	<input type="checkbox"/>	1
2	1	28CC1A40100001F	FRIGORÍFICO DO 1º ANDAR ESQ.	FREEZER 2	-10			<input type="checkbox"/>	1
3	19	2820C5A401000054	FRIGORÍFICO DO 1º ANDAR ESQ.	REFRIGIRATOR 1	7			<input type="checkbox"/>	1
4	11	28CFBCFF00000020	FRIGORÍFICO DO 1º ANDAR ESQ.	REFRIGIRATOR 2	7			<input type="checkbox"/>	1

Activate Configuration    Remove line nº:    RESET    SORT    EDIT/ Load more sensors

INOVNICA\_REGTEMPER-DI/SN: 80009 GRAPHIC OF SENSOR N: 7 @ FRIGORÍFICO DO 1º ANDAR ESQ. FREEZER 1 IN 20/02/2014 - FIRM

TEMPERATURE °C

DAY HOUR

CRC: 47    Print day Records    Print day Alarms    01 ↑ 2013 ↑ 19 ↑ FREEZER 1    Plot the Graphic    Print Graphic

02 ↓ 2014 ↓ 20 ↓ FREEZER 2

03 ↓ 2015 ↓ 21 ↓ REFRIGIRATOR 1

mm    aaaa    dd    Identification

2014 © INOVONICA

Also, if is needed to get the printouts lists of temperatures recorded at a certain date or the alarms list at that date, press Print day Records or Print day Alarms. Those lists will be in A4 format and look like:

---

**Printing aspect of sensor #7 Temperature log in A4 format on February 19, 2014.**

TEMPERATURE REGISTRATION  
LOGGER BRAND: INOVONICA  
MODEL: REGTEMPER-DI  
SN: 80009  
SOFTWARE VERSION: 3  
FIRM: LIDL  
SENSOR N°: 7 @ FRIGORÍFICO DO 1º ANDAR ESQ. FREEZER  
LOG DATE: 2014/02/19

READINGS	COMMENTS
18:00:22; -19,375;	
18:00:28; -19,250;	
18:00:28; -19,250;	
18:00:28; -19,250;	
18:00:30; -19,375;	
18:01:36; -19,250;	
18:01:38; -19,375;	
18:01:44; -19,250;	
18:01:46; -19,375;	
18:01:52; -19,250;	
18:01:54; -19,375;	
18:02:00; -19,250;	
18:02:02; -19,375;	
18:02:09; -19,250;	
18:02:11; -19,375;	
18:02:16; -19,250;	
18:02:18; -19,375;	
18:02:25; -19,250;	
18:02:25; -19,250;	
18:02:26; -19,375;	
18:02:33; -19,250;	
18:02:34; -19,375;	

---

**Printing aspect of Alarm log in A4 format on February 19, 2014.**

REGTEMPER - ALARM REGISTRATION  
BRAND: INOVONICA  
MODEL: REGTEMPER-DI  
SN: 80009  
SOFTWARE VERSION: 3  
COMPANY: LIDL  
ALARMS OF SENSOR NETWORK: 30009  
DATE OF THE ALARMS: 2014/02/19

ALARM READINGS	COMMENTS
18:12:58; 8,000;REFRIGIRATOR	
18:13:06; 8,000;REFRIGIRATOR	
18:13:26; -18,750;FREEZER	
18:13:30; 8,000;REFRIGIRATOR	
18:13:35; -18,750;FREEZER	
18:13:39; 8,000;REFRIGIRATOR	
18:13:43; -18,750;FREEZER	
18:13:55; 8,000;REFRIGIRATOR	
18:13:59; -18,750;FREEZER	
18:14:03; 8,000;REFRIGIRATOR	
18:14:07; -18,750;FREEZER	
18:14:11; 8,000;REFRIGIRATOR	
18:14:18; -18,750;FREEZER	
18:14:22; 8,000;REFRIGIRATOR	
18:14:26; -18,750;FREEZER	
18:14:30; 8,000;REFRIGIRATOR	
18:14:34; -18,750;FREEZER	
18:14:38; 8,000;REFRIGIRATOR	
18:15:02; 8,000;REFRIGIRATOR	
18:15:04; 4,625;REFRIGIRATOR	
18:15:09; 8,000;REFRIGIRATOR	
18:15:11; 4,500;REFRIGIRATOR	
12:48:10; 23,750;LABORATÓRIO15	
12:48:13; 23,750;LABORATÓRIO16	

## 9 - Hardware Unit (UI )

### 9.1 - Using the hardware Unit

Before putting the program running on the PC, the RJ45 male connector of the cable network must be connected to female terminal RJ45 of the UI .

Then, the UI will be connected to the USB port of the PC.

As soon as the REGTEMPER icon is clicked, program will start readings immediately.

The UI has two LEDs : one for temperature conversions signaling and other to show triggering of the alarms.

The temperature measurement LED goes off for approximately 1 second, indicating that a conversion temperature of a particular sensor is being made. When the Led is on, is paused during the time selected for the rhythm.

The Alarm LED flashes whenever a temperature exceeds the value set for the alarm. This signal also shows the activation of the external contact.

The hardware Unit (UI) is equipped also with a button to "reset" the alarm which is intended to prevent it to remain in operation for a long time.

The alarm can be stopped by the Alarm Reset button.

In the UI there is also a pair of clamping terminals for connecting the outdoor audiovisual alarm.

The ON / OFF contacts at terminals support 100V 500mA so, it should only be used to switch continuous currents within those values!

**! Never use these contacts to switch 220V mains.**

**For high power command use always a Relay, Contactor or a PLC interface!**

## 9.2 Scheme of the electronic interface

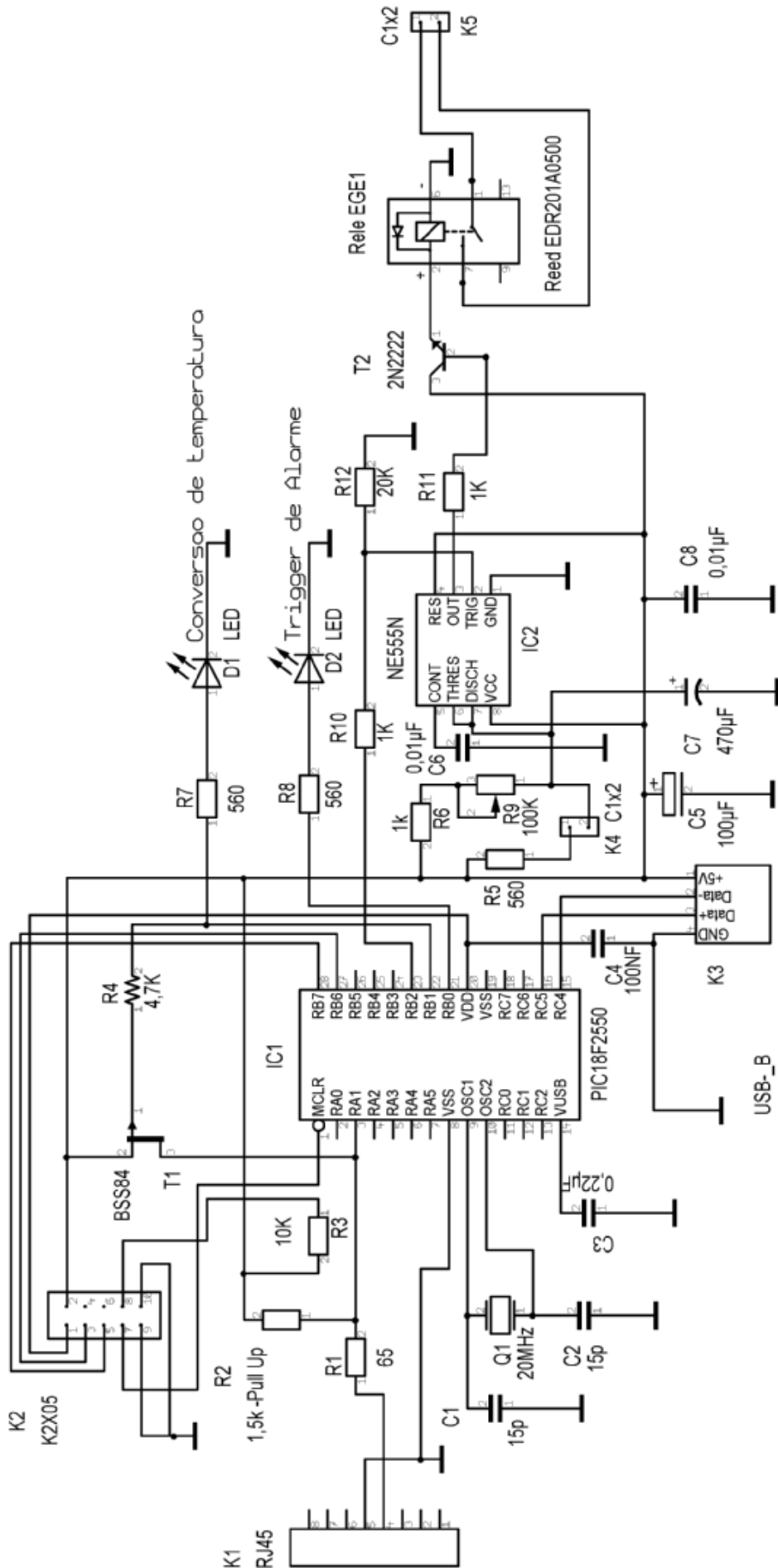

## 10 – FAQs

### 1 - How to install REGTEMPER ?

In the Pen supplied with the system is:

- 1 – REGTEMPER installer to install the program. Click twice to start the installation.
- 2 - REGINI.EXE Executable program that will be placed in the C: \ REGTEMPER - D \ Config . This executable allows you to send an SMS via the Internet through the website TextMagic.
- 3 – TextMagic Program, whose account is to be accessed for loading with configured User and Password.
- 5 - A usage agreement (EULA) of the model in use.
- 6 - A User's Guide in PDF.

### 2 – Why a message appears in red " Unread " in temperature window?

These message appears when there is no USB communication between the PC and the UI. This situation can happen when the port is not configured or when there are difficulties in recognizing the device. Is possible to occur with windows 8 and 8.1. Should be tried to use some other USB ports to get the hardware identification. Another solution is to configure the compatibility of the REGTEMPER.exe software as explained below.

### 3 - I'm using Windows 8 and the " Unread " always appears . What to do?

Windows 8 is an operating system with 64 -bit highly protected that creates compatibility problems with programs running well on XP, Vista and W7. You can try also to use the USB 3 Port with the configuration shown.

Go to the initial BIOS configuration program pressing F2 during booting and configure the USB ports like the pictures. In this example we have an ASUS mother board.

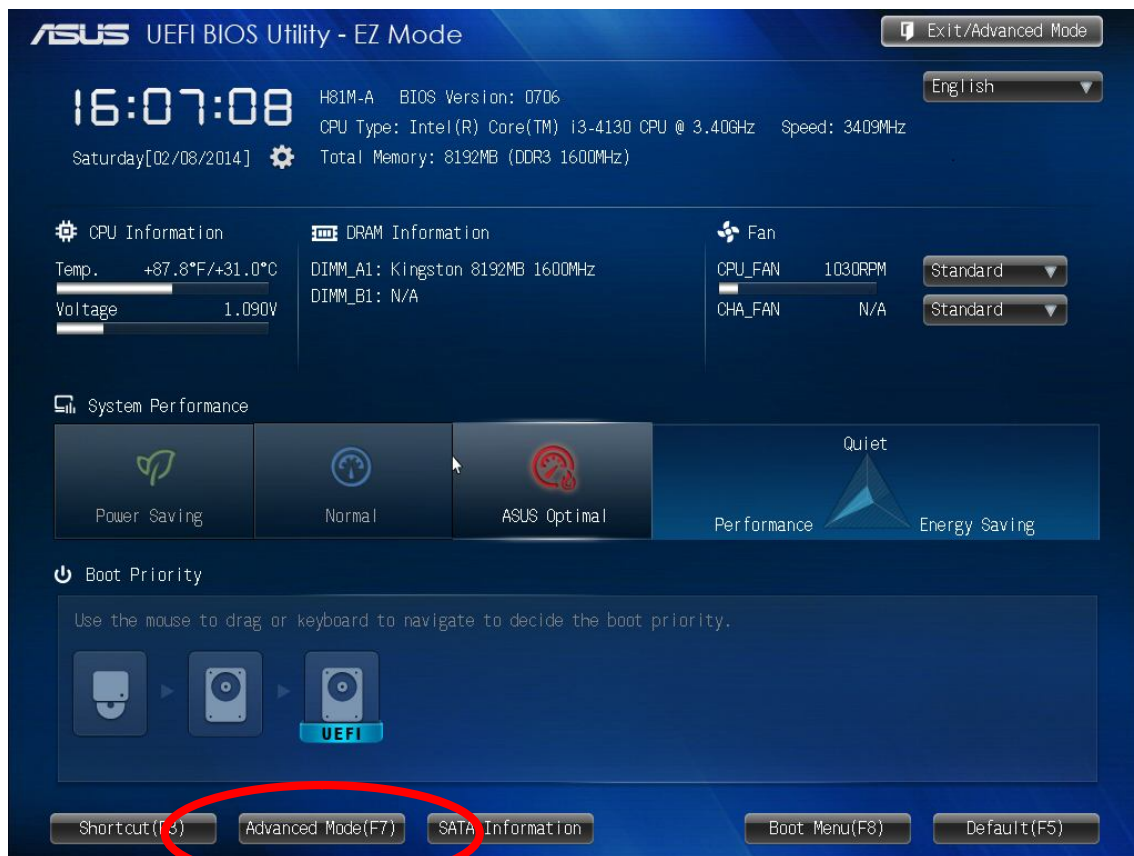

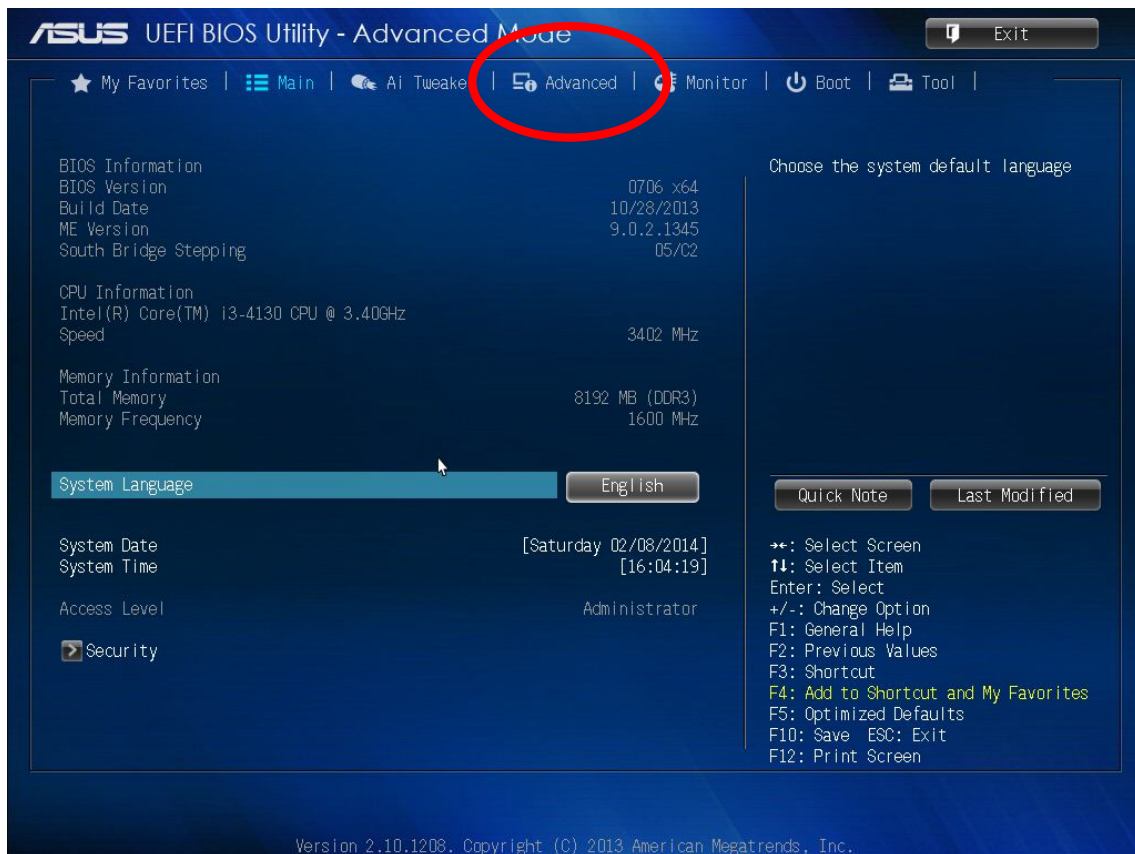
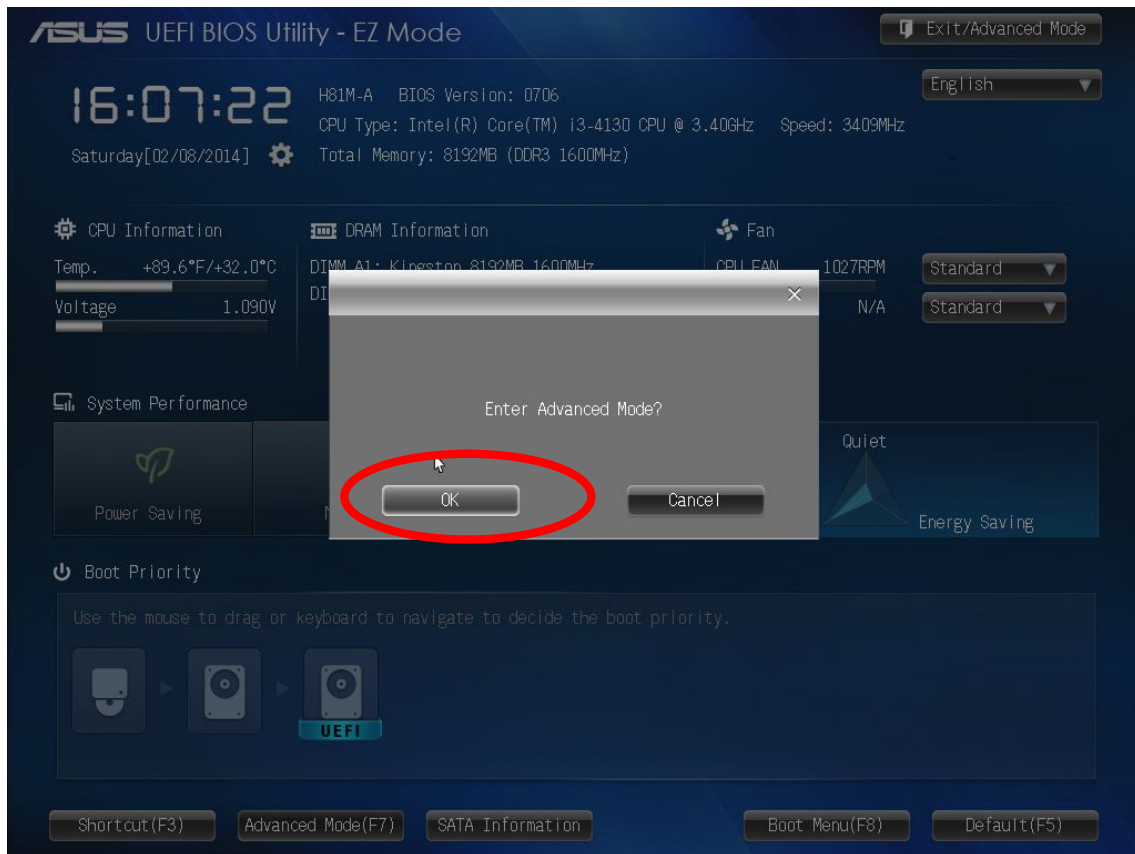

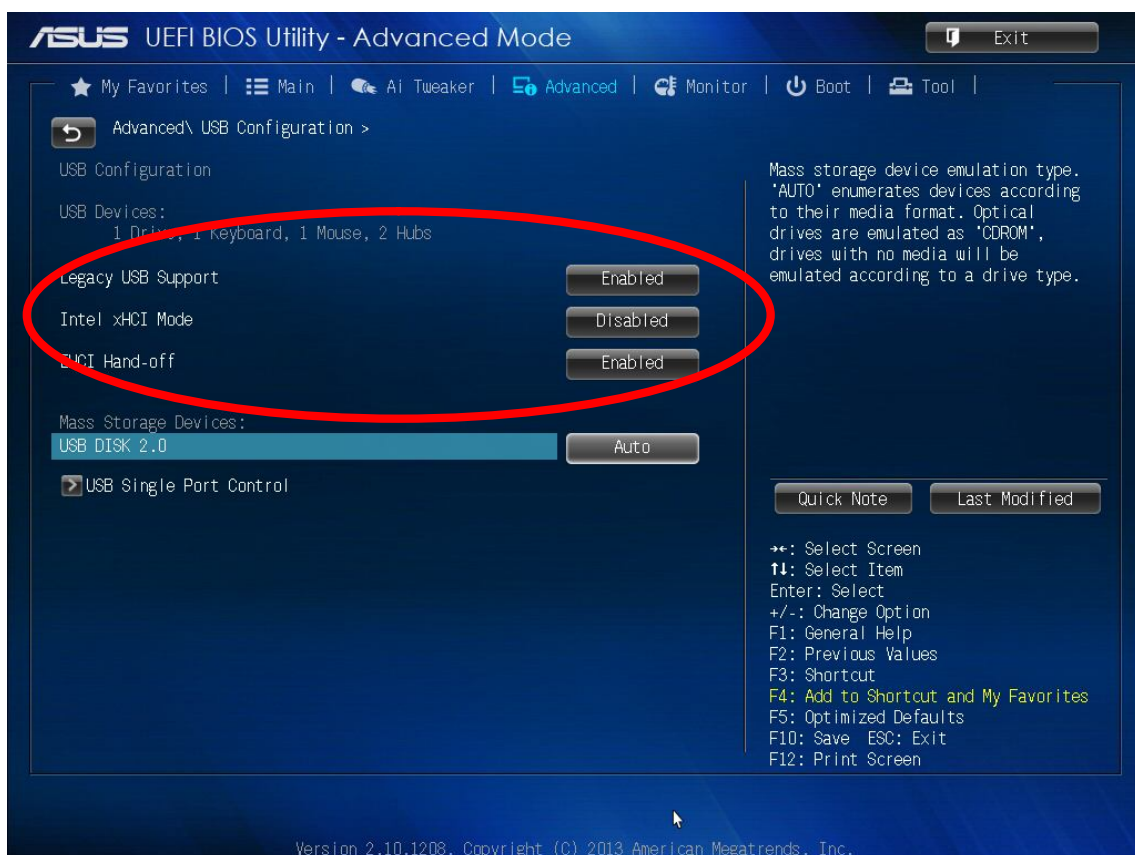
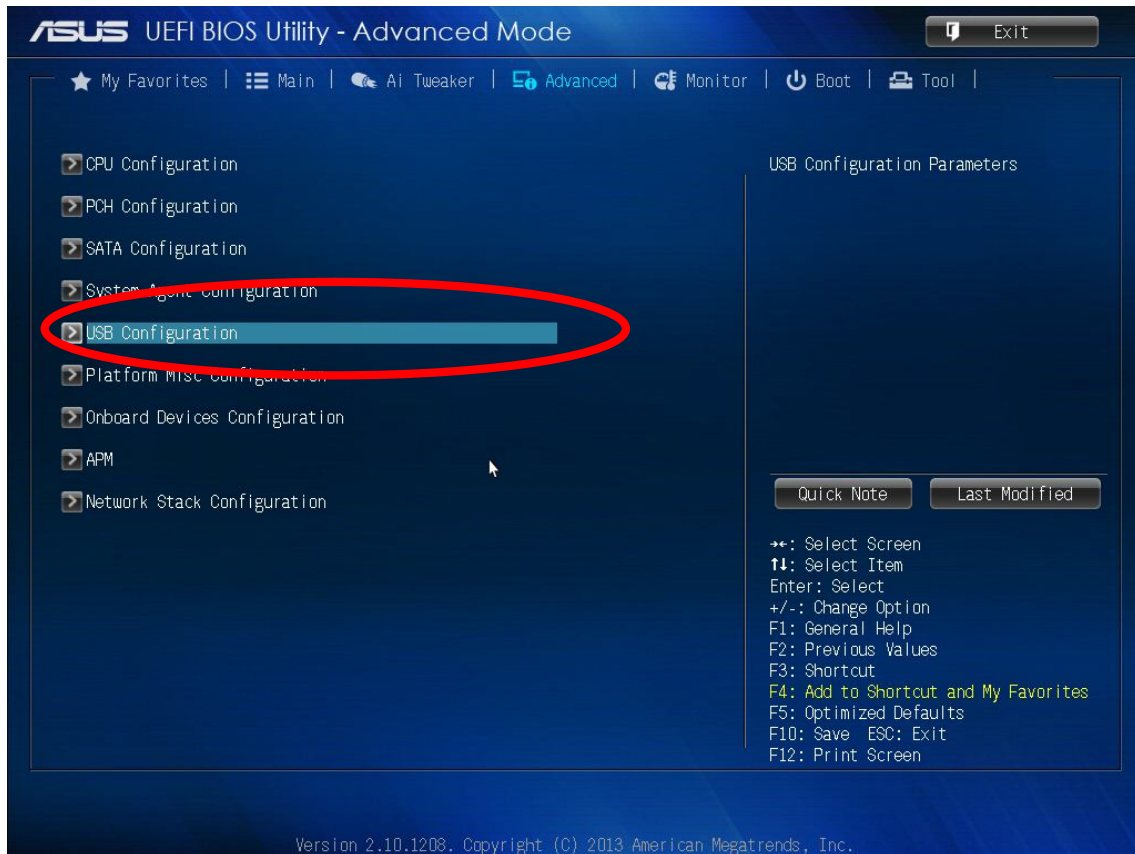

#### 4 - Even with the configuration of the USB ports in the BIOS it still appear readings "Unread". What to do?

If there is yet no communication, you should go to My Computer Icon (This PC) and look for the executable program REGTEMPER.exe in C: \ Program Files (x86) \ INOVONICA \ REGTEMPER-DI and put the mouse over the executable by clicking the right hand button to open the access panel of properties as shown in Figure.

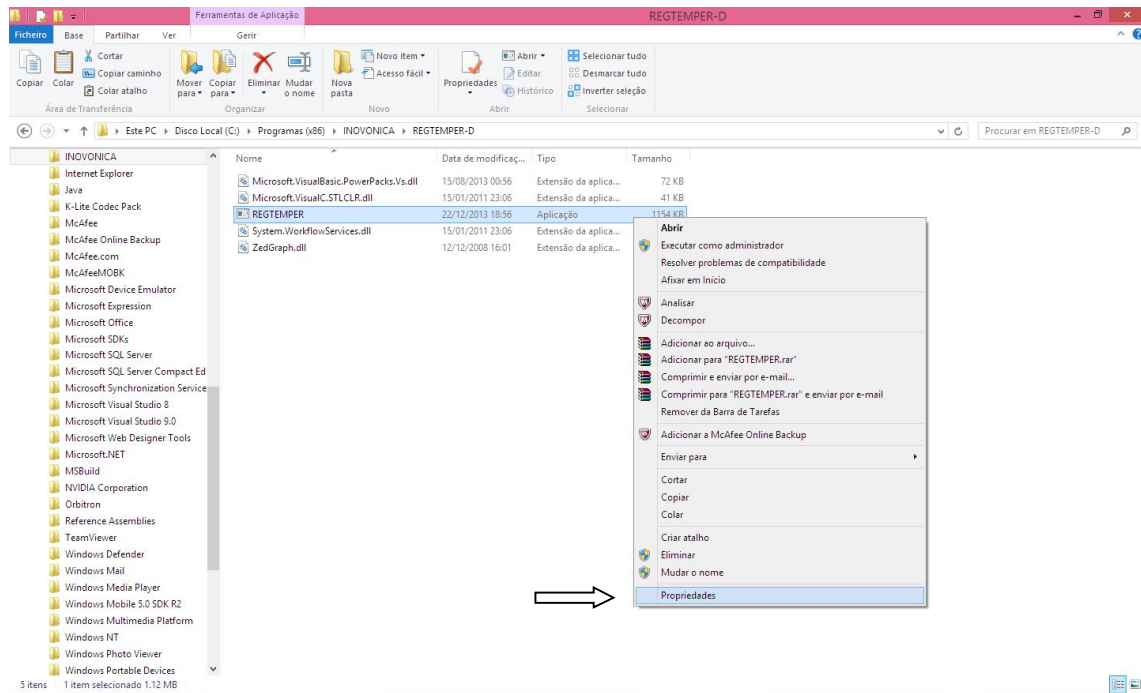

Under Compatibility panel, choose Run Windows 8 and Execute compatibility problems.

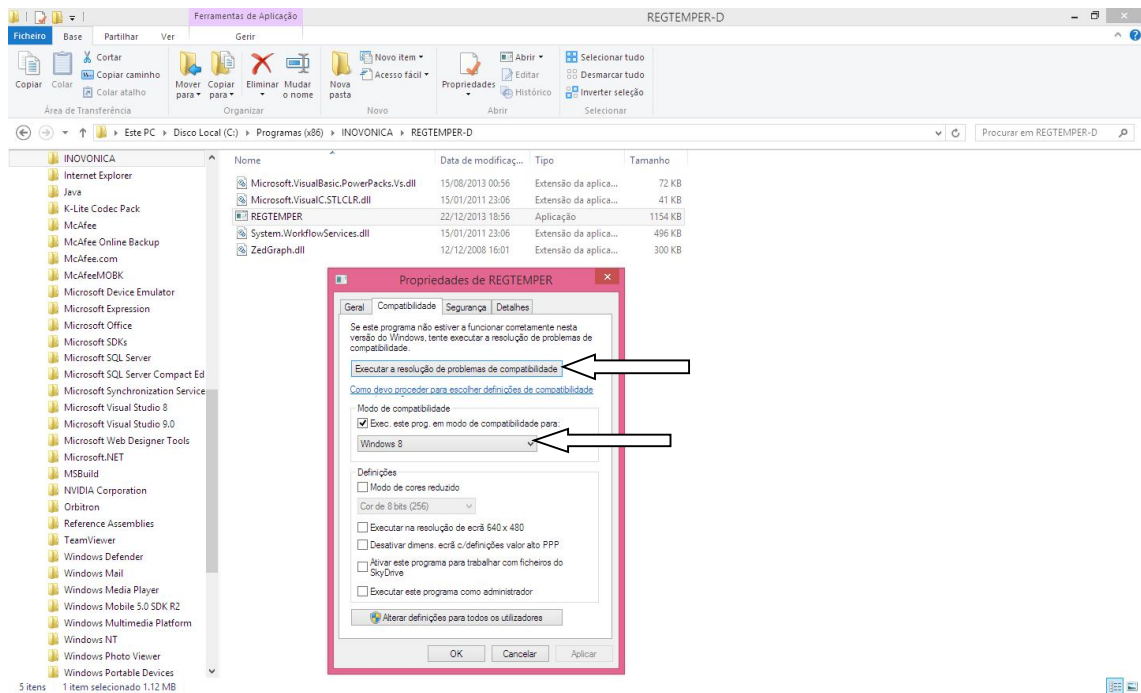

The window to select the option. Choose Try recommended settings.

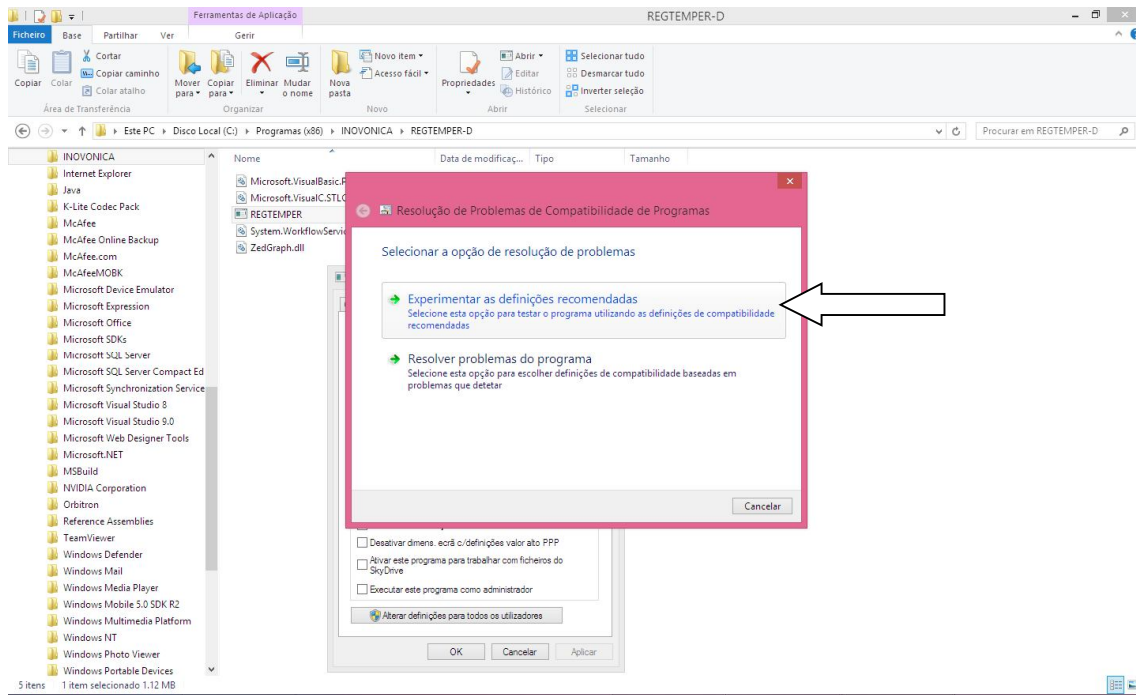

When the box of the figure below appears, do the test program. The REGTEMPER should normally start measuring the temperature of the sensor network.

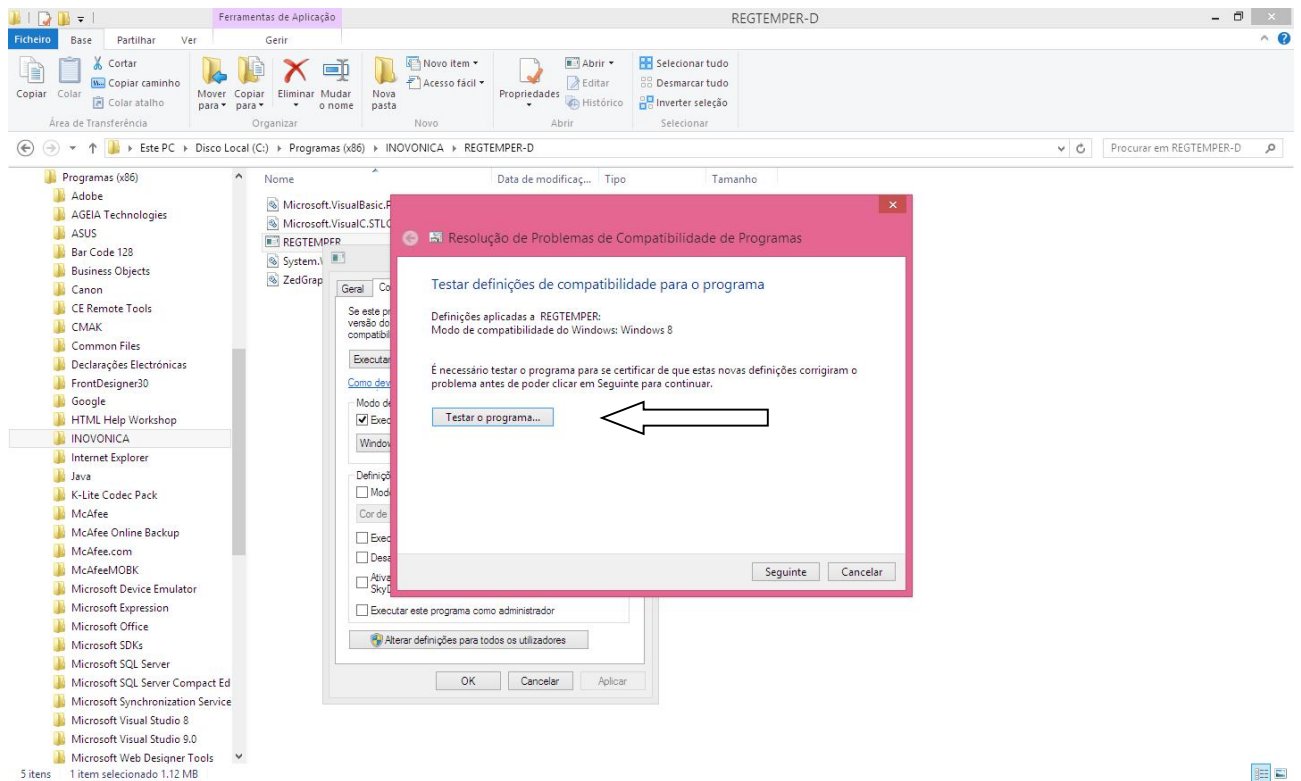

### 5 - Why a message appears in blue "Line off or shunted" ?

This message appears when no sensors are connected to the RJ45 network or when there is short circuit, open or when the network have more than 400 meters of cable is installed. Note that each sensor is given as having 2.5 meters weight (2m of cable whip and 0.5m ->22pF of sensor parasitic capacity) as previously explained.

You should try to connect only one sensor to the UI RJ45 and confirm if the hardware is in good conditions. If the information persists exit the program and restart again.

## 6 - Why an Error message appears in the Search Window saying to put only 1 sensor?

When performing a search of the sensor code, just put only that sensor to the UI RJ45 connector. Otherwise message will appears always.

## 7 - What means the message Click Yes if you are creating a boot file?

It can happen to open an XML file that is not compatible with your system configuration and the result is a Data Grid without information and the message like figure below.

The screenshot displays the 'TEMPERATURE LOGGER - INOVONICA / Model : REGTEMPER-DI v3 / SN: 80009' application. The interface includes a 'SEARCH WINDOW' with fields for Sensor number, Sensor code, Alarm temperature, Localization, Company, and Identification. A 'Sequence reading rate' section offers radio button options from 2 to 120 seconds. A 'READING TABLE' is visible with columns for Line, SENSOR N°, CODE, LOCALIZATION, IDENTIFICATION, ALARM, TEMPERATURE, Date Hour, Man, and NPA. An error dialog box is overlaid on the table, titled 'ERROR IN THE NETWORK FILE CONFIGURATION / REGTEMPER-D...', containing a warning icon and the text: '1 - SENSOR NETWORK DO NOT MATCHES. Verify File and Directory or remove the empty Line 1...'. The dialog has an 'OK' button. The bottom of the interface features buttons for 'Activate Configuration', 'Remove line n°', 'RESET', 'SORT', and 'EDIT/Load more sensors', along with a date/time selector and 'Print day Records'/'Print day Alarms' options.

Then, click OK, and then remove all the empty unnecessary lines .

When you remove the last line, a message appears saying that the zero line cannot be removed (see next figure) and to create a new sensor network.

Click YES (Sim) to create a fictitious boot net, because the software needs it as a first network to Start, because an improper net was opened.

You must Search for at least one sensor code and add it to the Data Grid to create the boot net or **Start File**. Save it in a personal folder or in the Backup folder.

Now you can go opening any network on the folder or create a New network.

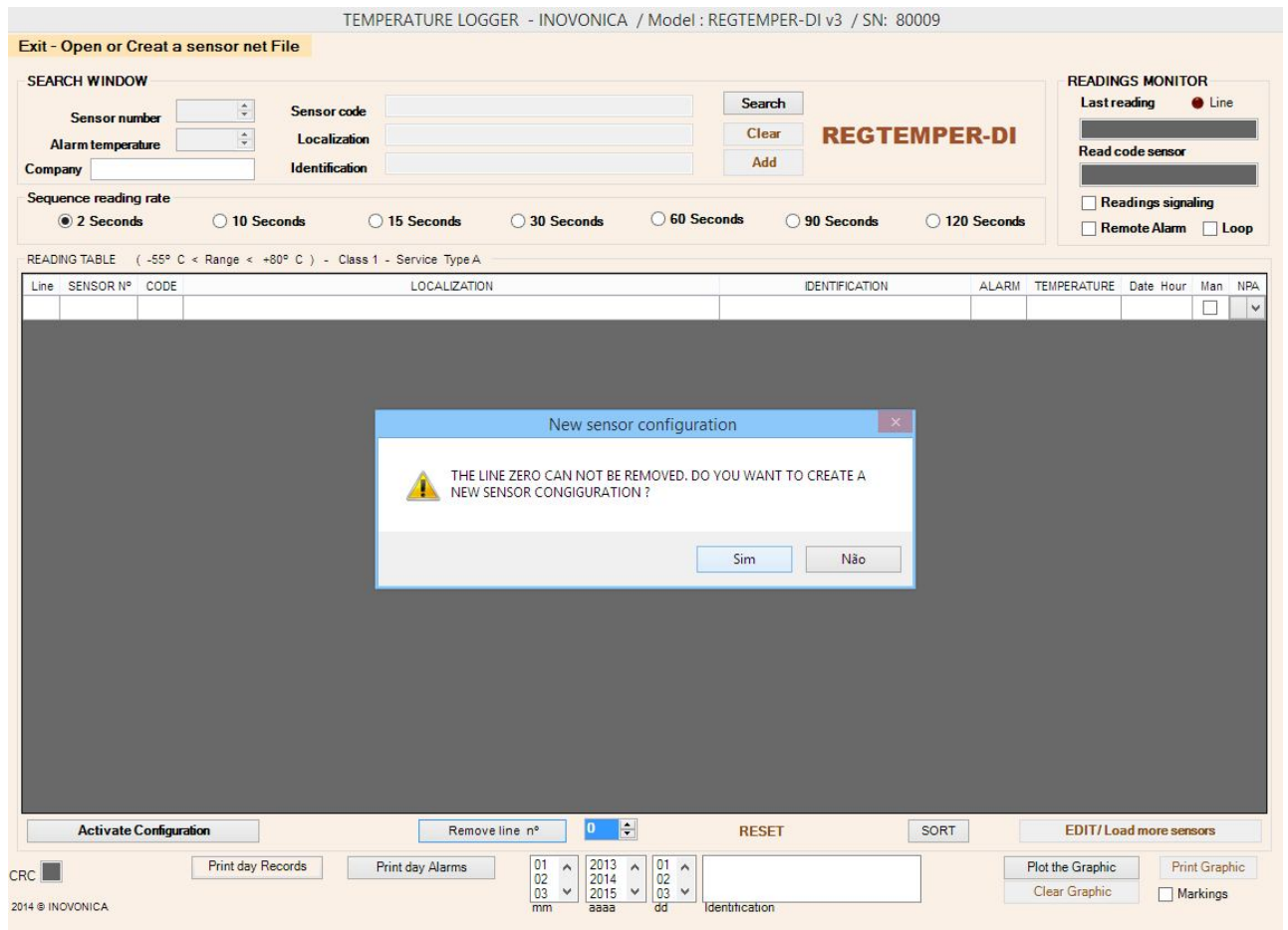

By default, the system already has "dummy " networks on the Back- up folder. When you Start REGTEMPER by clicking in the icon, it starts readings in one of these networks with logically values of **Unread**, because the codes of the sensors are not of your sensors. Open Menu -> New and create your sensor network as explained in ANNEX II .

### 8 - When I do Activate Configuration, is the configuration saved in the back-up folder?

No. Whenever you change a network through the edition, this change is not saved. It is just only a monitor version running to see if all is ok. If ok, you must save, in the Menu -> Save As selecting the network or a new name for this new configuration.

### 9 - I made a mistake changing the configuration of a network. Can I recover the previous network?

Yes. If the configuration was not recorded, just go, and get it back from the Back- up folder where file is unchanged. If you recorded the configuration with wrong settings, you must then go to the root of the folder C:\REGTEMPER-DI and open the last file Rede0000 with the date and time you started the editing in which mistaken as shown below. See next figure.

The software always saves the network present in the monitor and gave it the name Rede0000 with Day - Month- Year Hour -Minute - Second of the the moment you make the edition (EDIT / Load sensors).

With these protection, the system safeguards the settings of the previous Monitor network configuration that was wrongly edited and, thus, avoiding to load again all sensors of the destroyed network.

Warning: These safety files are cleaned automatically every 28th of each month to prevent memory waste.

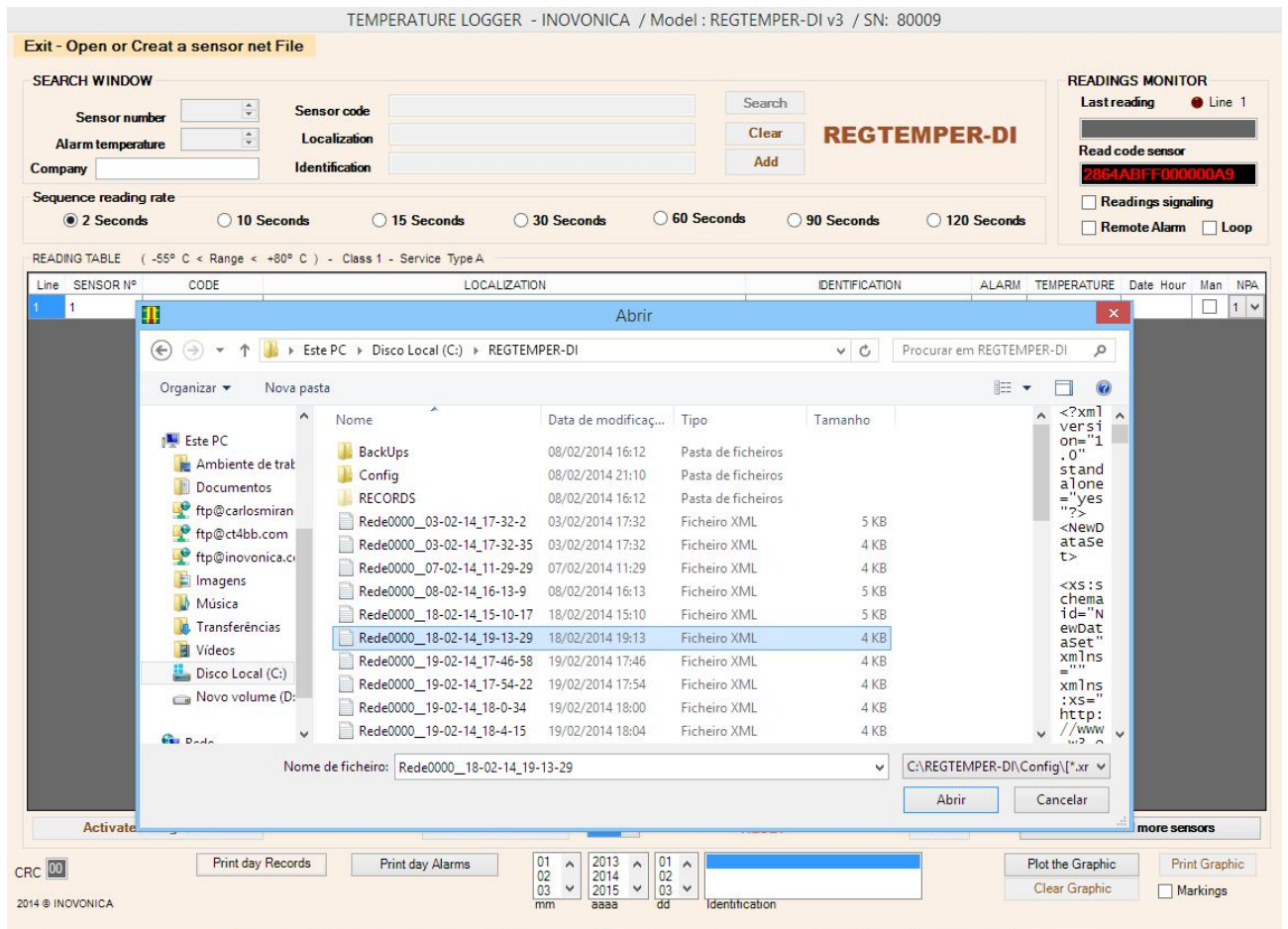

**10 - If I change ( by Editing ) the Localization or Identification of a sensor in the Data Grid the Graphic or readings are the same of previous registrations ?**

No. The change of name of the Localization or Identification represents a new situation for the sensor and, therefore, the starting up of new configuration, new readings and new graphics.

The new configuration does not allow to pick the previous graphics of the sensors of previous configuration. Therefore, whenever you change (Edit) the Data grid configuration, it is like creating a new network that must be saved with a new name.

Thus, the graphics of the previous configuration will be obtained by the network of that previous configuration.

You only can change the alarm settings without creating a new configuration .

**11 - Why when I EDIT to make a change in the panel it is not recorded ?**

All changes of text in the editable windows of the data Grid, should be followed by placing the Mouse in another window. If not, there is no recordable change.

**12 - Can I build a network by adding only the codes of the sensors picked up on the search ?**

**Yes** . However, it is good to enter the number marked on the sensor before inserting it into the Data Grid. For convenience, the sensors can be inserted in the numerical order indicated by the markers in them. But, when you do Sort, the grid will be sorted in reading order of the Localization and Identification and the numbering of the sensors will be shuffled.

### 13 - I want the system REGTEMPER to send an SMS. What do I have to do?

1 - You must double-click the program TextMagic that is in the supplied Pen, to install it on your computer. The program must be installed in the directory C: \ Program and never in C: \ Program Files (x86). The PC or Notebook where REGTEMPER is running, must be connected to the INTERNET.

2 - Then, after being installed, launch the program by entering the User and Pass Word configured for you.

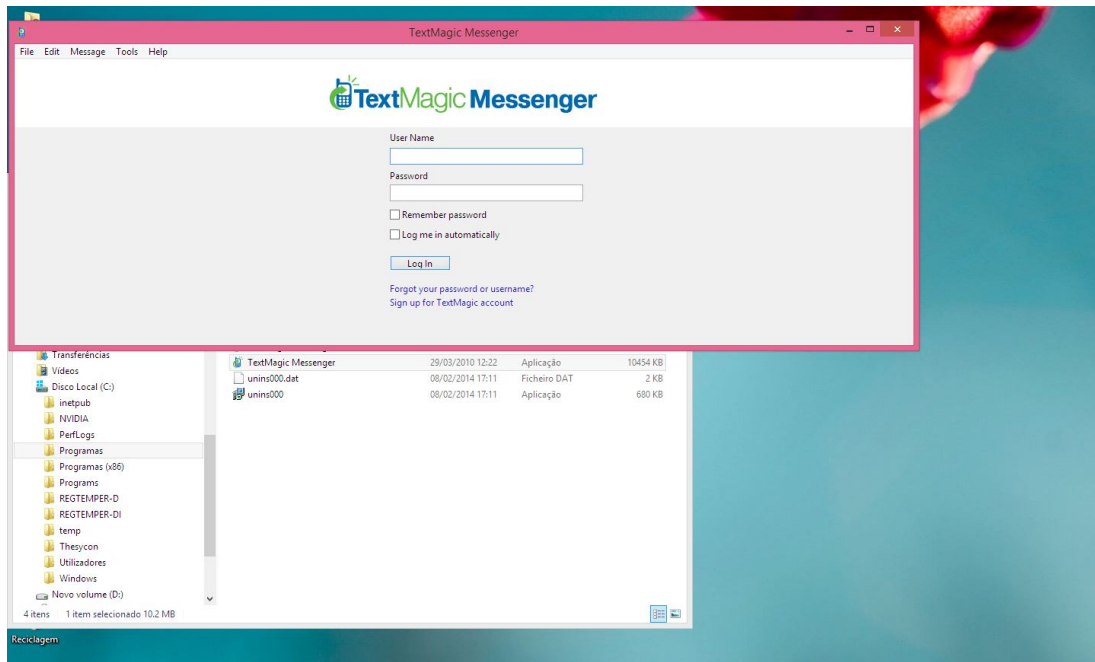

**Do not click the boxes Automatic Logging and Password Reminder otherwise the system will not work!**

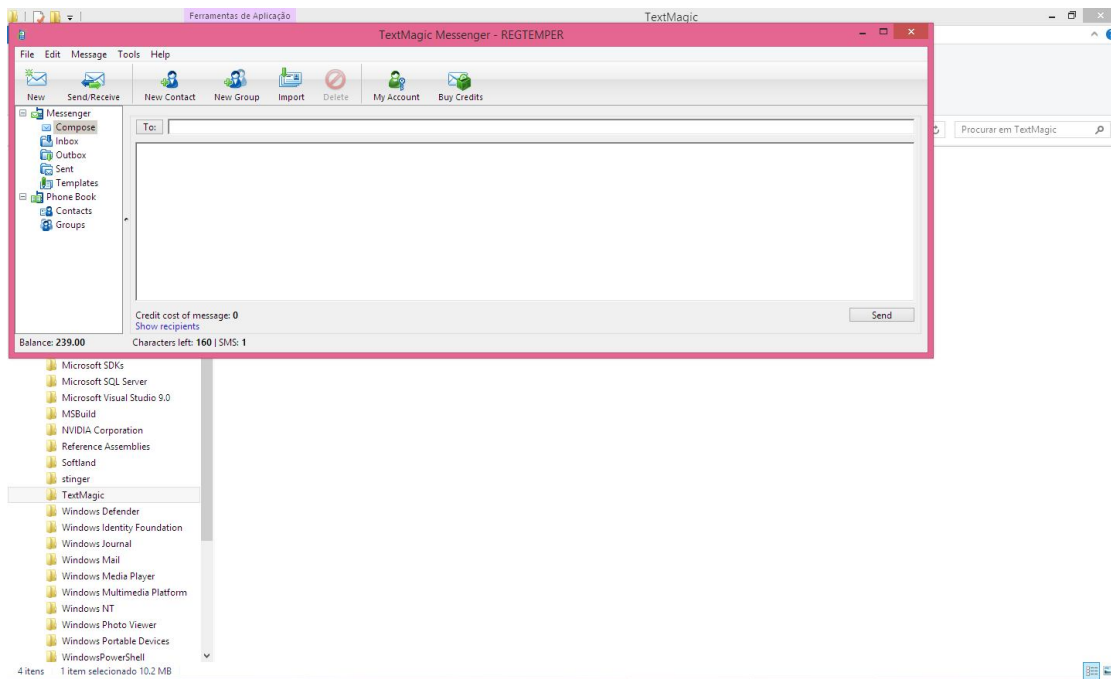

Then, select Contacts tab to edit and change the mobile phone number of the SUPERVISOR. Do not change the name SUPERVISOR which is the only recognized by the REGTEMPER/TextMagic.

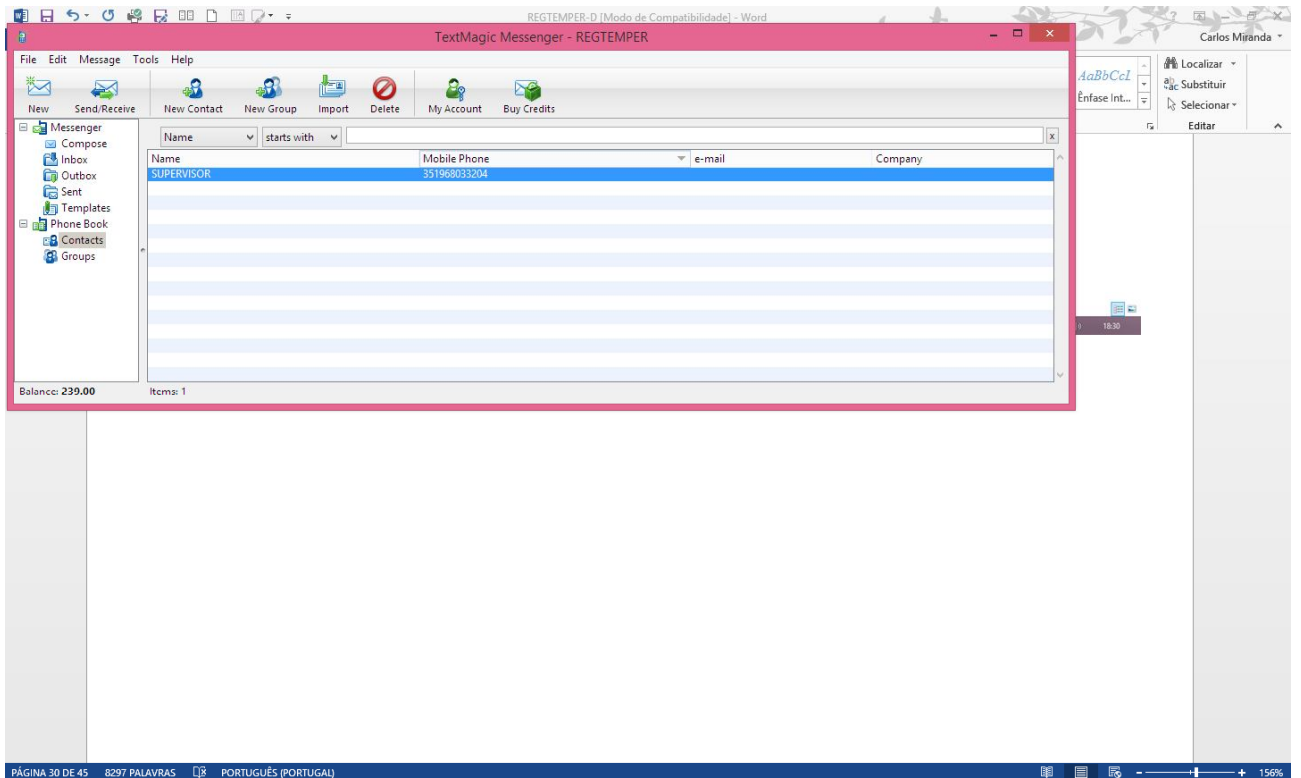

In the edit bar double click to display a window as shown in the next figure where you must insert your phone number or, preferably the mobile phone number.

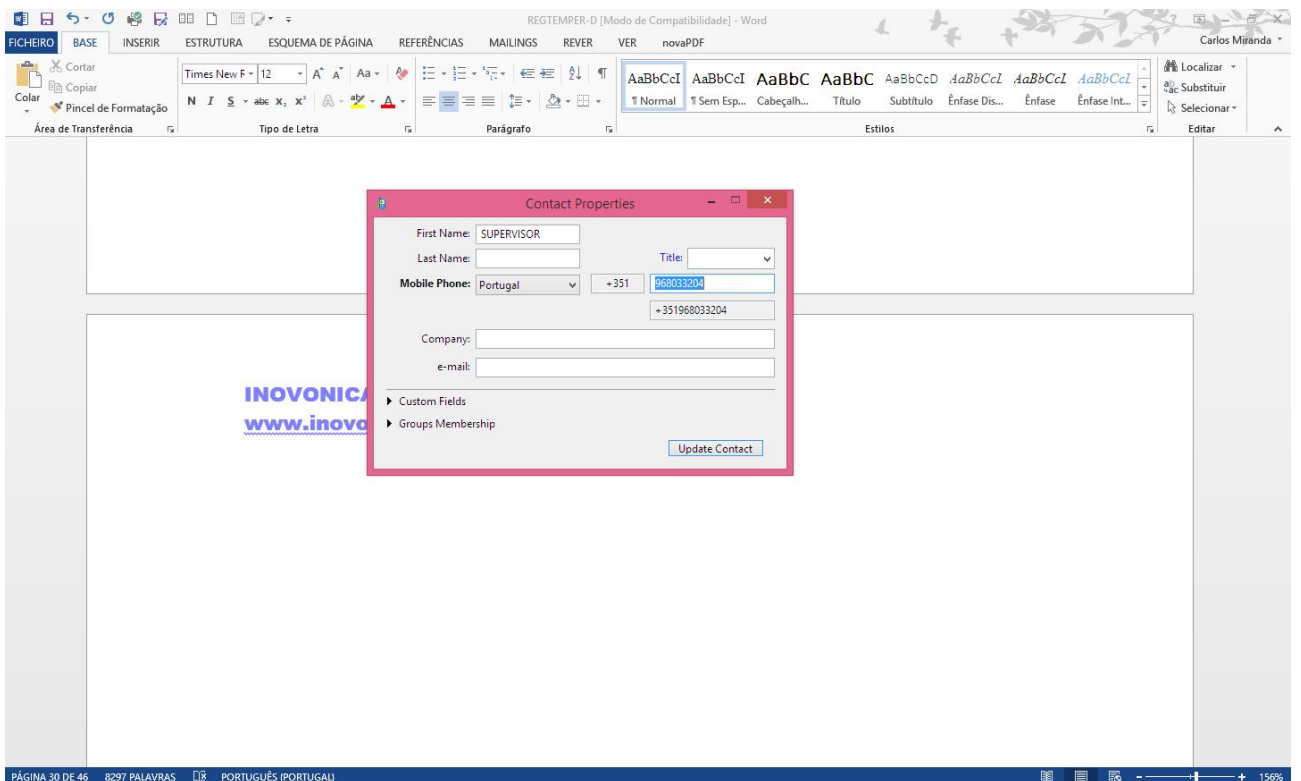

After the TextMagic configuration was finished, access the Pen and place a copy of the executable file **REGINI.exe** in the Config. folder in C: \ REGTEMPER-DI \ Config  
This application is executed by REGTEMPER to access the TextMagic Web site to perform the SMS alarm.

14 - When I try to get a chart, only a single line appears plotted. How can I solve this?

TEMPERATURE LOGGER - INOVONICA / Model : REGTEMPER-DI v3 / SN: 80009

Exit - Open or Create a sensor net File

SEARCH WINDOW

Sensor number: [ ] Sensor code: [ ] Search [ ]  
 Alarm temperature: [ ] Localization: [ ] Clear [ ]  
 Company: [ ] Identification: [ ] Add [ ]

REGTEMPER-DI

Sequence reading rate  
 2 Seconds  10 Seconds  15 Seconds  30 Seconds  60 Seconds  90 Seconds  120 Seconds

READING TABLE ( -55° C < Range < +80° C ) - Class 1 - Service Type A

Line	SENSOR Nº	CODE	LOCALIZATION	IDENTIFICATION	ALARM	TEMPERATURE	Date Hour	Man	NPA
1	7	2803A0FF0000009F	FRIGORÍFICO DO 1º ANDAR ESQ.	FREEZER 1	-10	-14,750	20/02/2014 10:37:54	<input type="checkbox"/>	1
2	1	28CCC1A40100001F	FRIGORÍFICO DO 1º ANDAR ESQ.	FREEZER 2	-10	Line off or shunted	20/02/2014 09:30:51	<input type="checkbox"/>	1
3	19	2820C5A401000054	FRIGORÍFICO DO 1º ANDAR ESQ.	REFRIGRATOR 1	7	9,500	20/02/2014 09:32:21	<input type="checkbox"/>	1
4	11	28CFBCFF00000020	FRIGORÍFICO DO 1º ANDAR ESQ.	REFRIGRATOR 2	7			<input type="checkbox"/>	1

Activate Configuration Remove line nº: [ ] RESET SORT EDIT/Load more sensors

INOVNICA\_REGTEMPER-DI v3, 80009 GRAPHIC OF SENSOR N. 19 @ FRIGORÍFICO DO 1º ANDAR ESQ. REFRIGRATOR 1 IN 20/02/2014 - FIRM

CRC [ ] Print day Records Print day Alarms [ ] 01 2013 19 FREEZER 1  
 [ ] 02 2014 20 FREEZER 2  
 [ ] 03 2015 21 REFRIGRATOR 1  
 mm aaaa dd Identification

Plot the Graphic Print Graphic  
 Clear Graphic Markings

2014 © INOVONICA

This line usually appears when the data read from the temporary decrypted temperature list is mismatched by the decimal symbol (comma or point). REGTEMPER uses the comma symbol as the decimal separator. You should go to Control Panel and select Regional Options to comma for the decimal separator.

TEMPERATURE LOGGER - INOVONICA / Model : REGTEMPER-DI v3 / SN: 80009

Exit - Open or Create a sensor net File

Todos os Itens do Painel de Controle

Região

Personalizar Formato

Exemplo  
 Positivo: 123456789.00 Negativo: -123456789.00

Separador decimal: [ ]  
 N.º de casas decimais: 2  
 Símbolo de agrupamento de dígitos: [ ]  
 Agrupamento de dígitos: 123456789  
 Símbolo de sinal negativo: -  
 Formato numérico negativo: -1.1  
 Apresentar zeros à esquerda: 0.7  
 Separador de lista: ;  
 Sistema de medida: Métrica  
 Dígitos padrão: 0123456789  
 Utilizar dígitos nativos: Nunca

Clique em Repor para restaurar as predefinições do sistema relativas a números, moeda, hora e data. Repor

OK Cancelar Aplicar

MONITOR

Last reading: [ ] Line 1  
 [ ] FREEZER 1  
 Read code sensor: 2803A0FF0000009F  
 Readings signaling  
 Remote Alarm  Loop

7:54 [ ] [ ]  
 0:51 [ ] [ ]  
 2:21 [ ] [ ]

2014 © INOVONICA PÁGINA 32 DE 49 8846 PALAVRAS PORTUGUÊS (PORTUGAL) 108%

## ANNEX I

### Number of the sensors

For better management and control of the sensors, the numbering is always in reference to the network where they are installed ie the last 3 digits of the serial number are REGTEMPER for the numbering of sensors and record the digits represent the network number.

The serial numbers REGTEMPER are in the thousands in 1000, 2000, 3000 etc. .... 12000.13000. and the final three zeros are for sensors.

For example:

A sensor with an equal number 25075 is the # 75 sensor network 25.

The technician who oversees multiple networks, you know that one sensor with the # 75 belongs to the network 25 installed on a given client.

The different numbering is recommended because each sensor is identified with a unique number that also matches its number of internal code. In case of a sensor malfunction, this number to the new replacement sensor will assign itself.

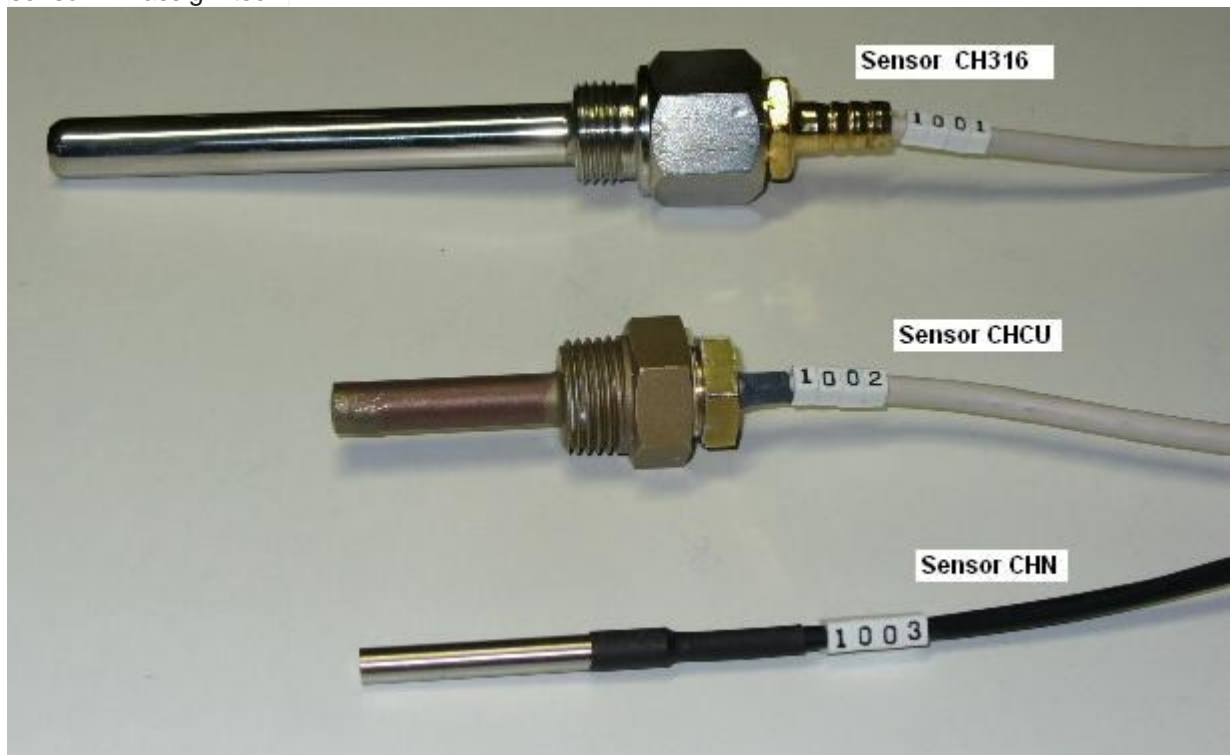

There are three types of sensors in the system. In the figure, sensors are numbered with respect to the system serial number 1000

### Wiring

The harness is made of networks with cables used in computer networks UTP CAT5 or CAT6, because the manufacturer of sensors designed them to networks with One Wire pairs of two wires and an impedance of 100 Ohms.

This type of cable also has the advantage of modularity and versatility in mounting the networks, because there on the market fitted with RJ45 connectors and various lengths.

REGTEMPER The pair used the Blue / Blue-White to communicate with sensors and connection of standard RJ45 plugs is the T-568B.

Although the use of cross cables (crossover) of the T-norm is not recommended 568A, its use does not affect the REGTEMPER network because Blue uses the same pair of pins 568B-T standard.

### Norm T-568B

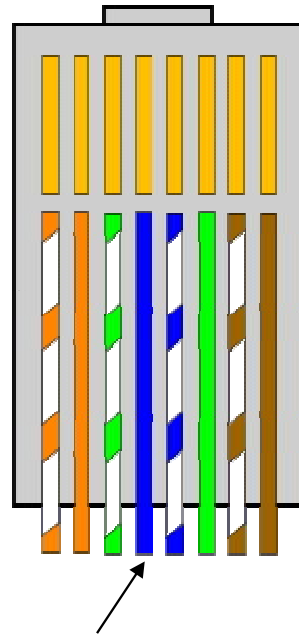

The blue pair is used for communicating with the sensors

How to estimate the cost of a network.

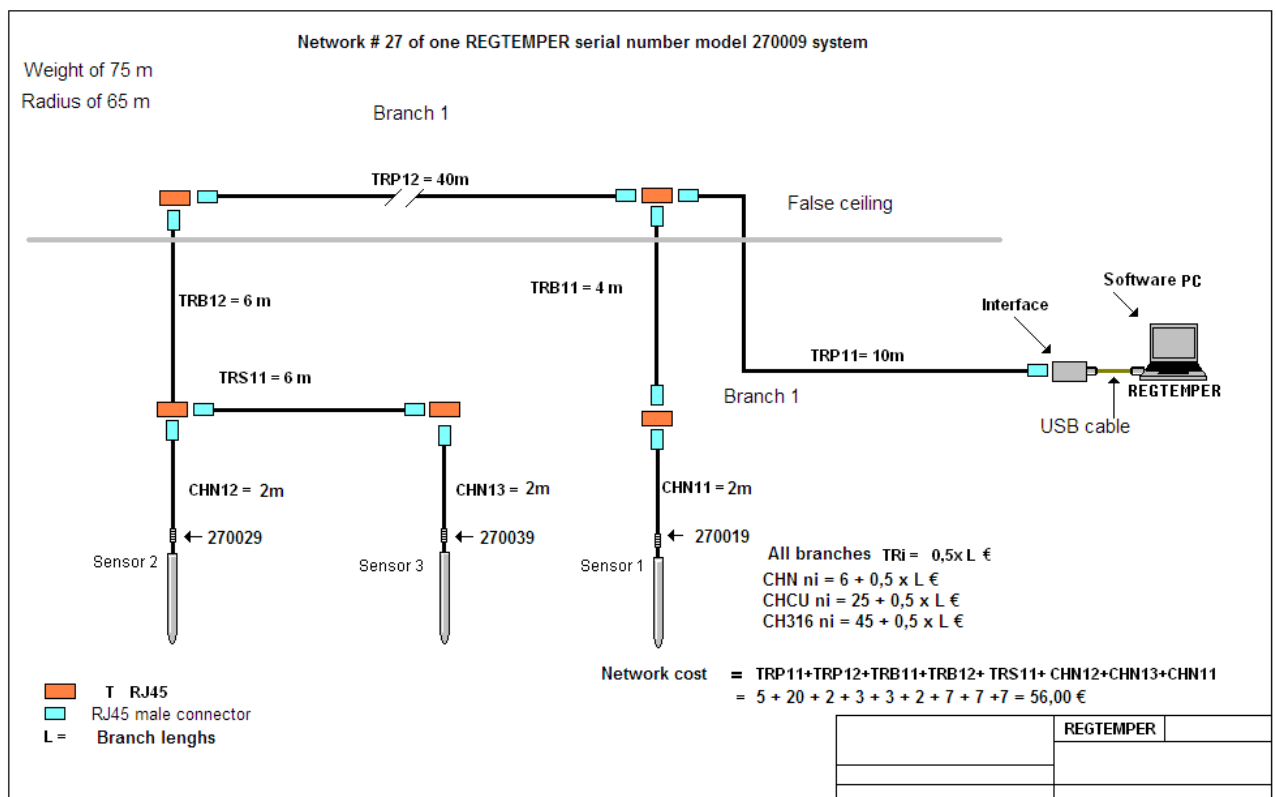

In schematic of the figure it can be seen that all trunks cost are  $(2 + 0,5 \times L) \text{ €}$ . Where L is the length of each portion and where all joints and T / s are included in the cost of the branches.

The CHN sensors cost €7,00 Note: The first 10 sensors are provided with the REGTEMPER and in this example, may cost  $3 \times \text{€}7,00 = \text{€}21,00$  to subtract to the value and we will obtain €35,00 for the entire materials for the cabling project. No men labor included.

INOVONICA

[www.inovonica.com](http://www.inovonica.com)

The cost of a network are easily determined by following these guidelines and calculations, because they represent the average market prices for the materials applied.

The scheme does not include hand labor in man / hours, because it is a value that depends on the installation difficulties of each case - rails holes in walls ceilings etc.

Cables for Trunks are acquired or constructed locally.

### **Installation of protections against EMI interference in data communications**

In installations where there is the possibility of frequent Electromagnetic Interference (EMI) that may affect the data in the cable, the CRC error detection produces a result the value of "Unread".

It will never appears an erroneous readings.

To reduce the number of "Unread" in strongly interfered areas, we can supply RJ45 unions equipped with ESD diodes that, apart from reducing the absence of data, also allows the installation to have more weight of cable network. In tests, we reached 500 meters weight with the system operating continuously without errors.

## ANNEX II – Using REGTEMPER

In ANNEX I we explained that after installing the software and the cable network with sensors, you will need to identify the codes of the sensors to create a new network. Go to Menu->New .

TEMPERATURE LOGGER INOVONICA - Model: REGTEMPER-DI / SN: 80009

Exit - Open or Create a sensor net File

- New Ctrl+N
- Open Ctrl+O
- Save as ...
- Exit

Sensor code: [ ] Search [ ]  
Localization: [ ] Clear [ ]  
Identification: [ ] Add [ ]

REGTEMPER-DI

Sequence reading rate  
 2 Seconds  10 Seconds  15 Seconds  30 Seconds  60 Seconds  90 Seconds  120 Seconds

READINGS MONITOR  
 Last reading ● Line 2  
**FREEZER**  
 Read code sensor  
**28CCC1A40100001F**  
 Readings signaling  
 Remote Alarm  Loop off

READING TABLE (-55° C < Range < +80° C) - Class 1 - Service Type A

Line	SENSOR Nº	CODE	LOCALIZATION	IDENTIFICATION	ALARM	TEMPERATURE	Date Hour	Man	NPA
1	7	2803A0FF0000009F	FRIGORIFICO DO 1º ANDAR ESQ.	FREEZER	-10	-18,375	19/02/2014 18:25:47	<input type="checkbox"/>	1
2	1	28CCC1A40100001F	FRIGORIFICO DO 1º ANDAR ESQ.	FREEZER	-10	-18,375	19/02/2014 18:25:42	<input type="checkbox"/>	1
3	19	2820C5A401000054	FRIGORIFICO DO 1º ANDAR ESQ.	REFRIGIRATOR	7	8,508	19/02/2014 18:25:44	<input type="checkbox"/>	1
4	11	28CFBCFF00000020	FRIGORIFICO DO 1º ANDAR ESQ.	REFRIGIRATOR	3	5,625	19/02/2014 18:25:46	<input type="checkbox"/>	1

Activate Configuration Remove line n° [ ] RESET SORT EDIT/Load more sensors

CRC [00] Print day Records Print day Alarms [01/02/03] [2013/2014/2015] [01/02/03] [FREEZER/FREEZER/REFRIGIRATOR] Plot the Graphic Print Graphic Clear Graphic Markings

2014 © INOVONICA

A clean grid will appear as shown to add your sensor data.

TEMPERATURE LOGGER INOVONICA - Model: REGTEMPER-DI / SN: 80009

Exit - Open or Create a sensor net File

SEARCH WINDOW  
 Sensor number [ ] Sensor code [ ] Search [ ]  
 Alarm temperature [ ] Localization [ ] Clear [ ]  
 Company [ ] Identification [ ] Add [ ]

REGTEMPER-DI

Sequence reading rate  
 2 Seconds  10 Seconds  15 Seconds  30 Seconds  60 Seconds  90 Seconds  120 Seconds

READINGS MONITOR  
 Last reading ● Line 4  
**REFRIGIRATOR**  
 Read code sensor  
**28CFBCFF00000020**  
 Readings signaling  
 Remote Alarm  Loop off

READING TABLE (-55° C < Range < +80° C) - Class 1 - Service Type A

Line	SENSOR Nº	CODE	LOCALIZATION	IDENTIFICATION	ALARM	TEMPERATURE	Date Hour	Man	NPA
								<input type="checkbox"/>	

Activate Configuration Remove line n° [0] RESET SORT EDIT/Load more sensors

CRC [00] Print day Records Print day Alarms [01/02/03] [2013/2014/2015] [01/02/03] [ ] Plot the Graphic Print Graphic Clear Graphic Markings

2014 © INOVONICA

The identification of the sensors is performed by inserting one by one in turn, in the RJ45 connector. Click the Search button and the sensor code will appear in the search window.

Exit - Open or Create a sensor net File

SEARCH WINDOW

Sensor number: 1 | Sensor code: 2864ABFF00000A9 | Search

Alarm temperature: | Localization: | Clear

Company: | Identification: | Add

Sequence reading rate:  2 Seconds  10 Seconds  15 Seconds  30 Seconds  60 Seconds  90 Seconds  120 Seconds

READING MONITOR

Last reading: Line 4

REFRIGIRATOR

Read code sensor: 28CFBCFF00000020

Readings signaling  Remote Alarm  Loop off

READING TABLE (-55° C < Range < +80° C) - Class 1 - Service Type A

Line	SENSOR N°	CODE	LOCALIZATION	IDENTIFICATION	ALARM	TEMPERATURE	Date Hour	Man	NPA
------	-----------	------	--------------	----------------	-------	-------------	-----------	-----	-----

Buttons: Activate Configuration, Remove line n°: 0, RESET, SORT, EDIT/ Load more sensors

CRC: 00 | Print day Records | Print day Alarms | Date/Time: 01/02/2013 01:02 | Identification: | Plot the Graphic | Print Graphic | Clear Graphic | Markings

2014 © INOVONICA

Maximum number of a REGTEMPER Network is 160.

At this point should also be inserted sensor number the Identification the Localization and the desired value of the alarm trigger. Finally, add all these data to the Data Grid.

Exit - Open or Create a sensor net File

SEARCH WINDOW

Sensor number: 1 | Sensor code: 2864ABFF00000A9 | Search

Alarm temperature: | Localization: | Clear

Company: | Identification: | Add

Sequence reading rate:  2 Seconds  10 Seconds  15 Seconds  30 Seconds  60 Seconds  90 Seconds  120 Seconds

READING MONITOR

Last reading: Line 4

REFRIGIRATOR

Read code sensor: 28CFBCFF00000020

Readings signaling  Remote Alarm  Loop off

READING TABLE (-55° C < Range < +80° C) - Class 1 - Service Type A

Line	SENSOR N°	CODE	LOCALIZATION	IDENTIFICATION	ALARM	TEMPERATURE	Date Hour	Man	NPA
1		2864ABFF00000A9			0				1

Buttons: Activate Configuration, Remove line n°: 1, RESET, SORT, EDIT/ Load more sensors

CRC: 00 | Print day Records | Print day Alarms | Date/Time: 01/02/2013 01:02 | Identification: | Plot the Graphic | Print Graphic | Clear Graphic | Markings

2014 © INOVONICA

For ease, data can be inserted later in the Data Grid by editing it and placing the Identification Localization and Alarm value.

INOVONICA

www.inovonica.com

Finally, you can sort sensors doing EDIT/Load sensors -> SORT. Sort of the sensors will be for Identification and localization.

To insert the data later, Edit the data Grid and write information in the respective window.

TEMPERATURE LOGGER INOVONICA - Model: REGTEMPER-DI / SN: 80009

Exit - Open or Creat a sensor net File

SEARCH WINDOW

Sensor number: 1, Sensor code: [ ], Search: [ ], Alarm temperature: [ ], Localization: [ ], Clear: [ ], Company: [ ], Identification: [ ], Add: [ ]

REGTEMPER-DI

Sequence reading rate:  2 Seconds,  10 Seconds,  15 Seconds,  30 Seconds,  60 Seconds,  90 Seconds,  120 Seconds

READING MONITOR

Last reading: ● Line 1

FREEZER

Read code sensor: 2803A0FF0000009F

Readings signaling,  Remote Alarm,  Loop off

READING TABLE (-55° C < Range < +80° C) - Class 1 - Service Type A

Line	SENSOR Nº	CODE	LOCALIZATION	IDENTIFICATION	ALARM	TEMPERATURE	Date Hour	Man	NPA
1	7	2803A0FF0000009F	FRIGORIFICO DO 1º ANDAR ESQ.	FREEZER	-10	-18,125	19/02/2014 18:31:48	<input type="checkbox"/>	1
2	1	28CCC1A40100001F	FRIGORIFICO DO 1º ANDAR ESQ.	FREEZER	-10	-18,125	19/02/2014 18:31:50	<input type="checkbox"/>	1
3	19	2820C5A401000054	FRIGORIFICO DO 1º ANDAR ESQ.	REFRIGIRATOR	7	8,750	19/02/2014 18:31:52	<input type="checkbox"/>	1
4	11	28CFBCFF00000020	FRIGORIFICO DO 1º ANDAR ESQ.	REFRIGIRATOR	3	8,125	19/02/2014 18:31:54	<input type="checkbox"/>	1

Activate Configuration, Remove line nº: 4, RESET, SORT, EDIT/Load more sensors

CRC: 00, Print day Records, Print day Alarms, 01/02/2013, 01/02/2014, 03/02/2015, mm, aaaa, dd, FREEZER, FREEZER, REFRIGIRATOR, Identification, Plot the Graphic, Print Graphic, Clear Graphic, Markings

2014 © INOVONICA

Do Activate Configuration -> Yes, as the window shown in the figure below.

TEMPERATURE LOGGER INOVONICA - Model: REGTEMPER-DI / SN: 80009

Exit - Open or Creat a sensor net File

SEARCH WINDOW

Sensor number: 1, Sensor code: [ ], Search: [ ], Alarm temperature: [ ], Localization: [ ], Clear: [ ], Company: [ ], Identification: [ ], Add: [ ]

REGTEMPER-DI

Sequence reading rate:  2 Seconds,  10 Seconds,  15 Seconds,  30 Seconds,  60 Seconds,  90 Seconds,  120 Seconds

READING MONITOR

Last reading: ● Line 3

REFRIGIRATOR

Read code sensor: 2820C5A401000054

Readings signaling,  Remote Alarm,  Loop off

READING TABLE (-55° C < Range < +80° C) - Class 1 - Service Type A

Line	SENSOR Nº	CODE	LOCALIZATION	IDENTIFICATION	ALARM	TEMPERATURE	Date Hour	Man	NPA
1	7	2803A0FF0000009F	FRIGORIFICO DO 1º ANDAR ESQ.	FREEZER	-10	-18,125	19/02/2014 18:32:27	<input type="checkbox"/>	1
2	1	28CCC1A40100001F	FRIGORIFICO DO 1º ANDAR ESQ.	FREEZER	-10	-18,125	19/02/2014 18:32:29	<input type="checkbox"/>	1
3	19	2820C5A401000054	FRIGORIFICO DO 1º ANDAR ESQ.	REFRIGIRATOR	7	8,750	19/02/2014 18:32:30	<input type="checkbox"/>	1
4	11	28CFBCFF00000020	FRIGORIFICO DO 1º ANDAR ESQ.	REFRIGIRATOR	3	8,125	19/02/2014 18:32:25	<input type="checkbox"/>	1

Activate Configuration, Remove line nº: 4, RESET, SORT, EDIT/Load more sensors

CRC: 00, Print day Records, Print day Alarms, 01/02/2013, 01/02/2014, 03/02/2015, mm, aaaa, dd, FREEZER, FREEZER, REFRIGIRATOR, Identification, Plot the Graphic, Print Graphic, Clear Graphic, Markings

2014 © INOVONICA

REGTEMPER-DI

THIS CONFIGURATION CLEARS THE PREVIOUS ONE! DO YOU CONFIRM?

OK also to create a Start File

Sim, Não

If you click yes the network is activated but not saved!

If you click No, everything goes back to the beginning with the appearance of the previous network in the Data Grid.

Networks must be saved in the Back-up folder, in Menu->Save as opening C:\REGTEMPER-DI\BackUps

TEMPERATURE LOGGER - INOVONICA / Model : REGTEMPER-DI v3 / SN: 80009

Exit - Open or Create a sensor net File

SEARCH WINDOW

Sensor number: [ ] Sensor code: [ ] Search: [ ]

Alarm temperature: [ ] Localization: [ ] Clear: [ ] **REGTEMPER-DI**

Company: [ ] Identification: [ ] Add: [ ]

Sequence reading rate:  2 Seconds  10 Seconds  15 Seconds  30 Seconds  60 Seconds  90 Seconds  120 Seconds

READING TABLE (-55° C < Range < +80° C) - Class 1 - Service Type A

Line	SENSOR N°	CODE	LOCALIZATION	IDENTIFICATION	ALARM	TEMPERATURE	Date Hour	Man	NPA
1	7	2803A0FF0000009F	FRIGORIFICO DO 1º ANDAR ESQ.	FREEZER 1	-10	-17,750	22/02/2014 18:25:33	<input type="checkbox"/>	1
2	1	28CCC1A40100001F	FRIGORIFICO DO 1º ANDAR ESQ.	FREEZER 2	-10	-18,000	22/02/2014 18:25:35	<input type="checkbox"/>	1
3	19	2820C5A401000054	FRIGORIFICO DO 1º ANDAR ESQ.	REFRIGIRATOR 1	7	9,125	22/02/2014 18:25:38	<input type="checkbox"/>	1
4	11							<input type="checkbox"/>	1

Guardar como

Este PC > Disco Local (C:) > REGTEMPER-DI >

Procurar em REGTEMPER-DI

Nome	Data de modificaç...	Tipo	Tamanho
BackUps	08/02/2014 16:12	Pasta de ficheiros	
Config	08/02/2014 21:10	Pasta de ficheiros	
RECORDS	08/02/2014 16:12	Pasta de ficheiros	
Rede0000_03-02-14_17-32-2	03/02/2014 17:32	Ficheiro XML	5 KB
Rede0000_03-02-14_17-32-35	03/02/2014 17:32	Ficheiro XML	4 KB
Rede0000_07-02-14_11-29-29	07/02/2014 11:29	Ficheiro XML	4 KB
Rede0000_08-02-14_16-13-9	08/02/2014 16:13	Ficheiro XML	5 KB
Rede0000_18-02-14_15-10-17	18/02/2014 15:10	Ficheiro XML	5 KB
Rede0000_18-02-14_19-13-29	18/02/2014 19:13	Ficheiro XML	4 KB
Rede0000_19-02-14_17-46-58	19/02/2014 17:46	Ficheiro XML	4 KB
Rede0000_19-02-14_17-54-22	19/02/2014 17:54	Ficheiro XML	4 KB

Nome de ficheiro: [ ]

Guardar com o tipo: C:\REGTEMPER-DI\Config[\*].xml

Abriu Cancelar

2014 © INOVONICA

To open security saved files do Menu->Open and go to C:\REGTEMPER-DI and chose the Net you want to recover from the last Editing error.

TEMPERATURE LOGGER - INOVONICA / Model : REGTEMPER-DI v3 / SN: 80009

Exit - Open or Create a sensor net File

New Ctrl+N

**Open Ctrl+O**

Save as ...

Exit

Company: [ ]

Sensor code: [ ] Search: [ ]

Localization: [ ] Clear: [ ] **REGTEMPER-DI**

Identification: [ ] Add: [ ]

Sequence reading rate:  2 Seconds  10 Seconds  15 Seconds  30 Seconds  60 Seconds  90 Seconds  120 Seconds

READING TABLE (-55° C < Range < +80° C) - Class 1 - Service Type A

Line	SENSOR N°	CODE	LOCALIZATION	IDENTIFICATION	ALARM	TEMPERATURE	Date Hour	Man	NPA
1	7	2803A0FF0000009F	FRIGORIFICO DO 1º ANDAR ESQ.	FREEZER 1	-10	-16,750	20/02/2014 10:59:50	<input type="checkbox"/>	1
2	1	28CCC1A40100001F	FRIGORIFICO DO 1º ANDAR ESQ.	FREEZER 2	-10	-15,375	20/02/2014 10:39:24	<input type="checkbox"/>	1
3	19	2820C5A401000054	FRIGORIFICO DO 1º ANDAR ESQ.	REFRIGIRATOR 1	7	9,500	20/02/2014 09:32:21	<input type="checkbox"/>	1
4	11	28CFBCFF00000020	FRIGORIFICO DO 1º ANDAR ESQ.	REFRIGIRATOR 2	7			<input type="checkbox"/>	1

Activate Configuration Remove line n° [ ] RESET SORT EDIT/Load more sensors

Print day Records Print day Alarms

01 2013 01 FREEZER 1

02 2014 02 FREEZER 2

03 2015 03 REFRIGIRATOR 1

mm aaaa dd Identification

Plot the Graphic Print Graphic

Clear Graphic Markings

2014 © INOVONICA

These Security saved files are created whenever you make edits or open new networks.  
These files avoids the loss of networks and time consuming job of having to reinstall all the sensors again.

TEMPERATURE LOGGER INOVONICA - Model: REGTEMPER-DI / SN: 80009

Exit - Open or Create a sensor net File

SEARCH WINDOW

Sensor number: 1    Sensor code:    Search

Alarm temperature:    Localization:    Clear

Company:    Identification:    Add

Sequence reading rate:  2 Second

READINGS MONITOR

Last reading: ● Line 2

**FREEZER**

Read code sensor

REGTEMPER-DI

Abrir

Este PC > Disco Local (C:) > REGTEMPER-DI

Organizar    Nova pasta

Nome	Data de modificaç...	Tipo	Tamanho
BackUps	08/02/2014 16:12	Pasta de ficheiros	
Config	08/02/2014 21:10	Pasta de ficheiros	
Rede0000_03-02-14_17-32-2	03/02/2014 17:32	Ficheiro XML	5 KB
Rede0000_03-02-14_17-32-35	03/02/2014 17:32	Ficheiro XML	4 KB
Rede0000_07-02-14_11-20-00	07/02/2014 11:20	Ficheiro XML	4 KB
Rede0000_08-02-14_16-11-00	08/02/2014 16:11	Ficheiro XML	5 KB
Rede0000_18-02-14_15-11-00	18/02/2014 15:11	Ficheiro XML	5 KB
Rede0000_18-02-14_19-13-29	18/02/2014 19:13	Ficheiro XML	4 KB
Rede0000_19-02-14_17-46-58	19/02/2014 17:46	Ficheiro XML	4 KB
Rede0000_19-02-14_17-54-22	19/02/2014 17:54	Ficheiro XML	4 KB
Rede0000_19-02-14_18-0-34	19/02/2014 18:00	Ficheiro XML	4 KB
Rede0000_19-02-14_18-4-15	19/02/2014 18:04	Ficheiro XML	4 KB
Rede0000_19-02-14_18-12-39	19/02/2014 18:12	Ficheiro XML	4 KB

Nome de ficheiro:    C:\REGTEMPER-DI\Config\\*.xml

Abrir    Cancelar

Activate Configuration    Remove line n°: 4    RESET    SORT    EDIT/Load more sensors

CRC 00    Print day Records    Print day Alarms    01 2013 01 FREEZER  
02 2014 02 FREEZER  
03 2015 03 REFRIGERATOR  
mm    aaaa    dd    Identification

2014 © INOVONICA

Safed security network.

TEMPERATURE LOGGER INOVONICA - Model: REGTEMPER-DI / SN: 80009

Exit - Open or Create a sensor net File

SEARCH WINDOW

Sensor number: 1    Sensor code:    Search

Alarm temperature:    Localization:    Clear

Company:    Identification:    Add

Sequence reading rate:  2 Seconds     10 Seconds     15 Seconds     30 Seconds     60 Seconds     90 Seconds     120 Seconds

READINGS MONITOR

Last reading: ● Line 2

**FREEZER**

Read code sensor

**28CCC1A40100001F**

Readings signaling     Remote Alarm     Loop off

REGTEMPER-DI

READING TABLE (-55° C < Range < +80° C) - Class 1 - Service Type A

Line	SENSOR N°	CODE	LOCALIZATION	IDENTIFICATION	ALARM	TEMPERATURE	Date Hour	Man	NPA
1	7	2803A0FF0000009F	FRIGORÍFICO DO 1º ANDAR ESQ.	FREEZER	-10	-17,875	19/02/2014 18:42:59	<input type="checkbox"/>	1
2	1	28CCC1A40100001F	FRIGORÍFICO DO 1º ANDAR ESQ.	FREEZER	-10	-17,875	19/02/2014 18:42:51	<input type="checkbox"/>	1
3	19	2820C5A401000054	FRIGORÍFICO DO 1º ANDAR ESQ.	REFRIGERATOR	10	9,125	19/02/2014 18:42:53	<input type="checkbox"/>	1
4	11	28CFBCFF00000020	FRIGORÍFICO DO 1º ANDAR ESQ.	REFRIGERATOR	10	6,875	19/02/2014 18:42:56	<input type="checkbox"/>	1
5	4	2859A0A401000099	LABORATORY FAN GLUED TO THE PC	NEAR THE FAN 4	30	MAINTENANCE		<input checked="" type="checkbox"/>	1
6	2	2847B1A401000060	LABORATORY FAN AIR FLOW	NEAR THE FAN 3	20	MAINTENANCE		<input checked="" type="checkbox"/>	1
7	5	283F59A4010000BD	LABORATORY PC FAN TABLE	NEAR THE FAN 2	20	MAINTENANCE		<input checked="" type="checkbox"/>	1
8	6	28373EA40100005C	LABORATORY PCFAN TABLE	NEAR THE FAN 1	25	MAINTENANCE		<input checked="" type="checkbox"/>	1
9	15	2842D8FF0000008E	SENSOR A 100 METROS	LABORATÓRIO7	27	MAINTENANCE		<input checked="" type="checkbox"/>	1
10	18	28A019FF00000026	SENSOR A 106 METROS	LABORATÓRIO9	25	MAINTENANCE		<input checked="" type="checkbox"/>	1
11	10	282273FF0000000E	SHOPPING CENTER "OLIMPUS" "ICE CREAM SHOP"	SHOWCASE CHOCOLATE	25	MAINTENANCE		<input checked="" type="checkbox"/>	4
12	12	28D77AE601000064	SHOPPING CENTER "OLIMPUS" "ICE CREAM SHOP"	SHOWCASE VANILLA	28	MAINTENANCE		<input checked="" type="checkbox"/>	1
13	21	28856BA401000072	SHOPPING CENTER "OLIMPUS" "ICE CREAM SHOP"	SHOWCASE PISTACHIOS	22	MAINTENANCE		<input checked="" type="checkbox"/>	1
14	17	2864ABFF000000A9	SHOPPING CENTER "OLIMPUS" "ICE CREAM SHOP"	FREEZER 153	25	MAINTENANCE		<input checked="" type="checkbox"/>	1
15	13	284C6DFF00000000	SHOPPING CENTER "OLIMPUS" BUTCHER "NEW AGE"	MEAT SHOWCASE STEAK PO...	24	MAINTENANCE		<input checked="" type="checkbox"/>	1
16	20	28F0B4A401000030	SHOPPING CENTER "OLIMPUS" BUTCHER "NEW AGE"	FREEZER 24	25	MAINTENANCE		<input checked="" type="checkbox"/>	1
17	14	285E68A4010000A2	SHOPPING CENTER "OLIMPUS" BUTCHER "NEW AGE"	REFRIGERATOR 2	25	MAINTENANCE		<input checked="" type="checkbox"/>	1

Activate Configuration    Remove line n°: 13    RESET    SORT    EDIT/Load more sensors

CRC 00    Print day Records    Print day Alarms    01 2013 01 FREEZER  
02 2014 02 FREEZER  
03 2015 03 REFRIGERATOR  
mm    aaaa    dd    Identification

2014 © INOVONICA

It can be seen that in this network there are several yellow sensors which represents maintenance signaling. This is done by editing the Data Grid and then signaling the Man window. In Column NPA (Number Assigned Route) it will be placed the branch number where the sensor is installed. For plotting and printing of graphics or the Listing of registered values, select the corresponding sensor date and identification. If the selected file or directory does not exists, a message will be displayed as shown below

TEMPERATURE LOGGER INOVONICA - Model: REGTEMPER-DI / SN: 80009

Exit - Open or Creat a sensor net File

SEARCH WINDOW

Sensor number: 1, Alarm temperature: [dropdown], Company: [text box]

Sensor code: [text box], Localization: [text box], Identification: [text box]

Sequence reading rate:  2 Seconds,  10 Seconds,  15 Seconds,  30 Seconds,  60 Seconds,  90 Seconds,  120 Seconds

READING TABLE ( -55° C < Range < +80° C ) - Class 1 - Service Type A

Line	SENSOR N°	CODE	LOCALIZATION	IDENTIFICATION	ALARM	TEMPERATURE	Date Hour	Man	NPA
1	7	2803A0FF0000009F	FRIGORÍFICO DO 1º ANDAR ESQ.	FREEZER	-10	-17,875	19/02/2014 18:43:44	<input type="checkbox"/>	1
2	1	28CCC1A40100001F	FRIGORÍFICO DO 1º ANDAR ESQ.	FREEZER	-10	-17,875	19/02/2014 18:43:46	<input type="checkbox"/>	1
3	19	2820C5A401000054	FRIGORÍFICO DO 1º ANDAR ESQ.	REFRIGIRATOR	10	9,250	19/02/2014 18:43:41	<input type="checkbox"/>	1
4	11	28CFB0CF00000020	FRIGORÍFICO DO 1º ANDAR ESQ.	REFRIGIRATOR	10	6,875	19/02/2014 18:43:43	<input type="checkbox"/>	1

GRAPHICS - REGTEMPER-DI

DIRECTORY OR FILE DO NOT EXISTS. TRY AGAIN.

Print day Records, Print day Alarms

If the file exists there will be a print as shown

document.pdf - Adobe Reader

Arquivo Editar Visualizar Janela Ajuda

TEMPERATURE REGISTRATION

LOGGER BRAND: INOVONICA  
MODEL: REGTEMPER-DI  
SN: 80009  
SOFTWARE VERSION: 3  
FIRM:  
SENSOR N°: 7 @ FRIGORÍFICO DO 1º ANDAR ESQ. FREEZER  
LOG DATE :2014/02/19

READINGS	COMMENTS
18:00:22; -19,375;	
18:00:28; -19,250;	
18:00:28; -19,250;	
18:00:28; -19,250;	
18:00:30; -19,375;	
18:01:36; -19,250;	
18:01:38; -19,375;	
18:01:44; -19,250;	
18:01:46; -19,375;	
18:01:52; -19,250;	
18:01:54; -19,375;	
18:02:00; -19,250;	
18:02:02; -19,375;	
18:02:09; -19,250;	
18:02:11; -19,375;	
18:02:16; -19,250;	
18:02:18; -19,375;	
18:02:25; -19,250;	
18:02:25; -19,250;	
18:02:26; -19,375;	
18:02:33; -19,250;	
18:02:34; -19,375;	
18:02:41; -19,250;	
18:02:43; -19,250;	
18:02:49; -19,250;	
18:02:50; -19,250;	
18:02:57; -19,250;	
18:02:58; -19,250;	
18:03:05; -19,250;	
18:03:05; -19,250;	
18:03:06; -19,250;	
18:03:12; -19,125;	
18:03:14; -19,250;	

If the option is to plot a Graphic it will be displayed in the monitor like the figure.

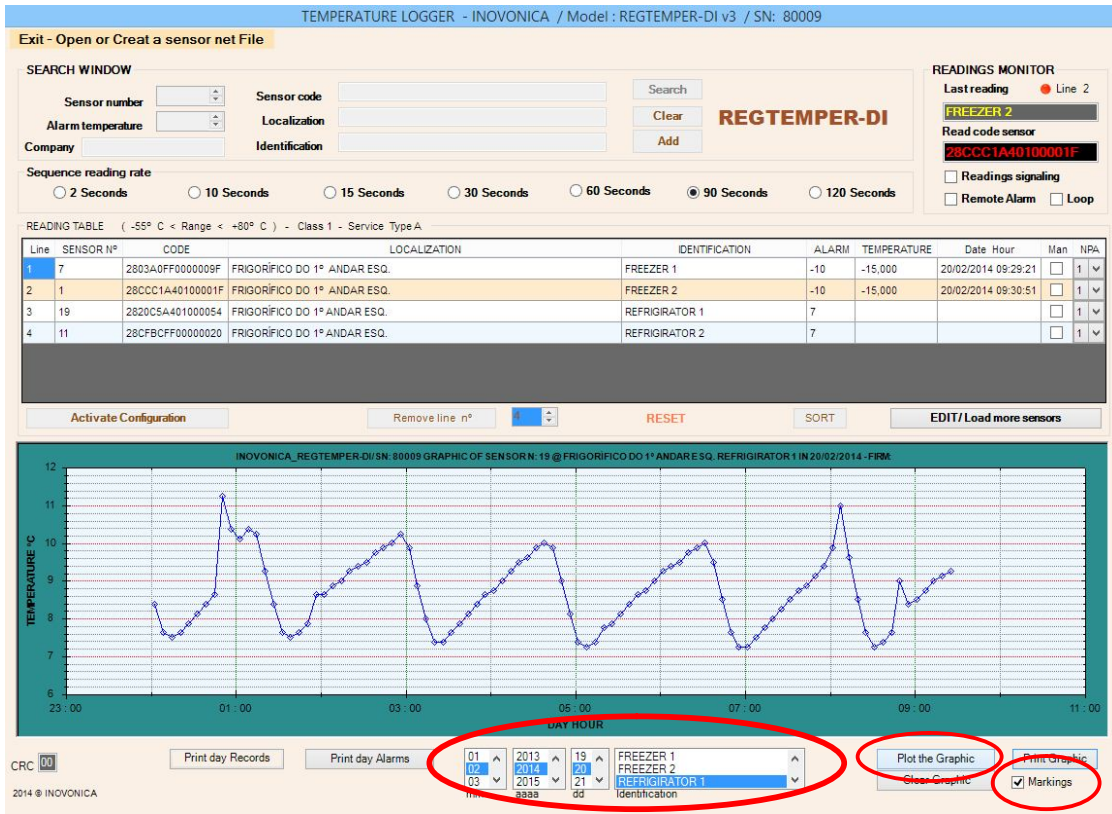

Graph with Markings by selecting the Markings window.

The discontinuities show the openings of the refrigerator doors to 01:50 am and 07:30.

**For the removal of grid lines**, because the sensor has broken down or, because it was removed, removing will be done by Editing the Data Grid, and selecting the line number click the **Remove-line n°**.

If all lines are removed from the grill, a message appears asking if you want to create a new network.

If not, the network that was in the previous frame Readings will reappear.

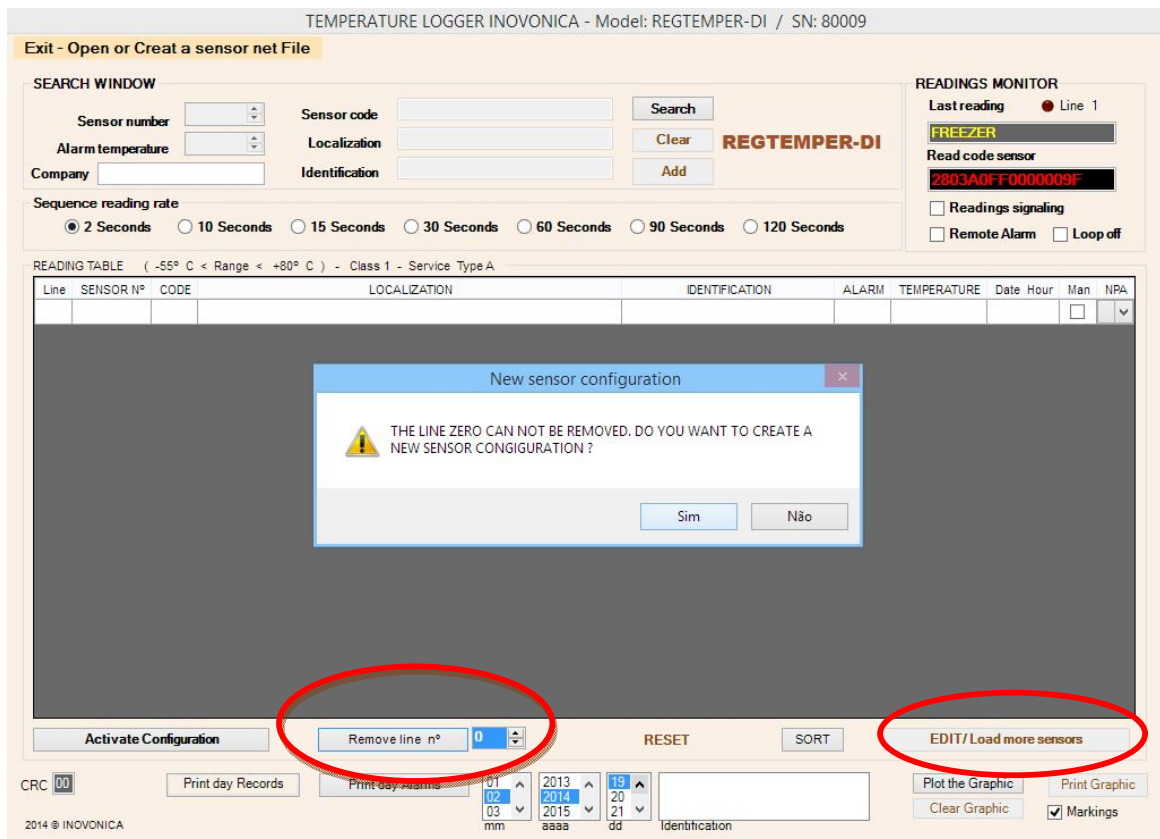

**TABLE I**  
**Corrosive Environments Causing Intergranular Attack of Sensitized Austenitic Stainless Steels**

Media	Concentration, wt %	Temperature, F	Length of Exposure	AISI Type of Stainless Steel	Type of Exposure	Method of Sensitization
Acetic Acid	99.6	245	2 yr	316	Field	as-cast
Acetic Acid with Salicylic Acid	55-75 .02-0.3	220	—	316	Field	as-welded
Acetic Acid	20	Boiling	503 hr	316	Lab	2 hr at 1250 F
Chromic Acid	10	Boiling	110 hr	304, 316	Lab	*
Citric Acid	20	Boiling	1082 hr	316	Lab	2 hr at 1250 F
Ferric Chloride	5	Boiling	—	316	Lab	*
Ferric Chloride	25	Cold	17 hr	302	Lab	*
Formic Acid (inhibited with ferric ions)	10	Boiling	2400 hr	304	Lab	*
Hydrofluoric Acid & Ferric Sulfate	1.8-2 6-8	170	15 min	302	Field	flame annealed
Lactic Acid	50	Boiling	240 hr	304	Lab	*
Lactic Acid	85	Boiling	96 hr	304	Lab	2 hr at 1250 F
Nitric Acid	65	Boiling	240 hr	316	Lab	2 hr at 1250 F
Nitric Acid	12.5	Boiling	96 hr	302	Lab	*
Nitric Acid	55	Boiling	144 hr	304	Lab	*
Nitric Acid	70	210	2400 hr	302, 304	Lab	*
Nitric Acid & Hydrofluoric Acid	10 12 1.5	140	5 16 mo	304, 316	Field	as-welded
Oxalic Acid	10	Boiling	120 hr	316	Lab	2 hr at 1250 F
Phosphoric Acid	60, 70 & 85	Boiling	96 hr	304, 316	Lab	*
Phosphoric Acid	50	Boiling	264 hr	316	Lab	2 hr at 1250 F
Sodium Bisulfate (inhibited with ferric ions)	10	Boiling	2400 hr	304	Lab	*
Sulfamic Acid (inhibited with ferric ions)	10	Boiling	2400 hr	304	Lab	*
Sulfuric Acid	0.5	Boiling	24-48 hr	302, 316	Lab	*
Sulfuric Acid	3	Boiling	15 hr	316	Lab	*
Sulfuric Acid (air free)	10	158	96 hr	316, 317	Lab	*
Sulfuric Acid	30	96	72 hr	316	Lab	2 hr at 1250 F
Mixed Sulfuric Acid and Nitric Acid	0.6 0.4	212	—	309	Field	Too slowly cooled by spray quenching
Sulfuric Acid and Ferrous Sulfate	9 7	65	21 days	304	Specimens in Field	Welded & stress relieved 2 hr at 1250 F

\* Specific heat treatment not given but varied from 1 to 1000 hours at temperatures from 1000 F to 1400 F. Warren<sup>1</sup>